

TECHNICAL DATA

Size		
Heat output 165°F EWT	BTUh	max.
		med.
		min.
Rated at Standard air volume 68°F DB		LWT°F
Total net cooling capacity at 165°F EWT	watts	max.
		med.
		min.
Rated at Standard air volume 80.6/66.2°F (DB/WB)		LWT°F
Sensible net cooling capacity at 45°F EWT	watts	max.
		med.
		min.
Rated at Standard air volume 80.6/66.2°F (DB/WB)		LWT°F
Volumetric Air Flow	CFM	max.
		med.
		min.
Sound pressure level	db(A)	max.
		med.
		min.
Flowrate	UsGPM	
Measured power	watts	
Measured current	A	

2-PIPE HEAT EXCHANGER

Size	070	090	110	130	150
Heat output 165°F EWT	6671	14250	19545	24905	29623
	4944	10013	16466	17430	23686
	2567	5776	12133	10108	20925
Rated at Standard air volume 68°F DB	150	150	150	150	150
	2151	4592	7030	8825	10109
	1864	3950	6098	8217	8730
Total net cooling capacity at 165°F EWT	1093	2441	4011	6002	5586
	55	55	55	55	55
	1765	3755	5455	7350	8409
Rated at Standard air volume 80.6/66.2°F (DB/WB)	55	55	55	55	55
	1383	2889	4623	6483	6934
	772	1800	3049	4913	4688
Sensible net cooling capacity at 45°F EWT	55	55	55	55	55
	96	189	272	340	383
	67	149	217	268	277
Rated at Standard air volume 80.6/66.2°F (DB/WB)	33	92	147	218	251
	1	1	1	1	1
	41	42	43	42	44
Volumetric Air Flow					
	34	35	34	35	37
	25	28	29	26	27
Sound pressure level					
	0,72	1,5	2,1	2,6	3,15
	17	38	41	42	43
Flowrate					
Measured power					
Measured current					

4-PIPE HEAT EXCHANGER

Size	070	090	110	130	150
Heat output 165°F EWT	3723	7669	10235	12645	17135
	2854	6545	8665	10622	14250
	1733	4558	6483	9275	12933
Rated at Standard air volume 68°F DB	150	150	150	150	150
	1958	4203	6483	8023	9628
	1412	3500	5167	5616	7091
Total net cooling capacity at 165°F EWT	963	2182	3722	4814	6320
	55	55	55	55	55
	1670	3434	5005	6322	7477
Rated at Standard air volume 80.6/66.2°F (DB/WB)	55	55	55	55	55
	1187	2696	4076	4653	5678
	674	1031	1547	1956	5039
Sensible net cooling capacity at 45°F EWT	55	55	55	55	55
	89	171	243	312	355
	60	136	196	241	273
Rated at Standard air volume 80.6/66.2°F (DB/WB)	30	82	128	199	240
	1	1	1	1	1
	41	42	43	42	44
Volumetric Air Flow					
	34	35	34	35	37
	25	28	29	26	27
Sound pressure level					
	0,63	1,32	1,99	2,52	2,8
	17	38	41	42	43
Flowrate					
Measured power					
Measured current					

1 Tangential fan with motor (230 V - 1 Ph - 50 Hz) with continuously directed condenser, capacity 2.5 µF. Safety with automatic reset. IP 41. Earthing supplied. Rollers. Working pressure: 10 bars.

(1) Normal calculation and selection at perceptible cooling capacity and preferably at medium speed.

(2) Measured model: model BRMW with casing and standard heat exchanger. Height: 1 m from the air exhaust grille. The sound pressure is influenced by the dimensions of the room, the reverberation time and other sound sources.

DIMENSIONS

BRMW: BRiza Metal Wall
Wall mounted model

Size	27.5"	35.5"	43.5"	51"	59"
	(070)	(090)	(110)	(130)	(150)
A	28.5"	36"	44"	52"	60"
	(72.3)	(92.3)	(112.3)	(132.3)	(152.3)

BRBI: BRiza Build In
Built in wall or ceiling
mounted model

Size	27.5"	35.5"	43.5"	51"	59"
	(070)	(090)	(110)	(130)	(150)
B	15"	23"	31"	38.5"	46"
	(37.8)	(57.8)	(77.8)	(97.8)	(117.8)

2-PIPE

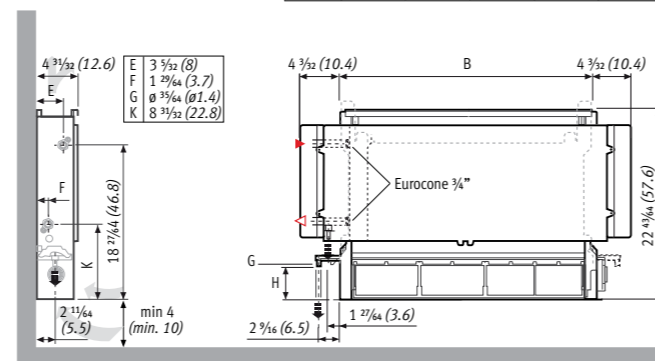
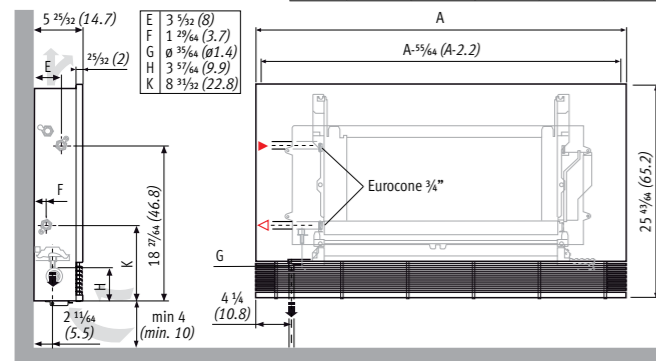

4-PIPE

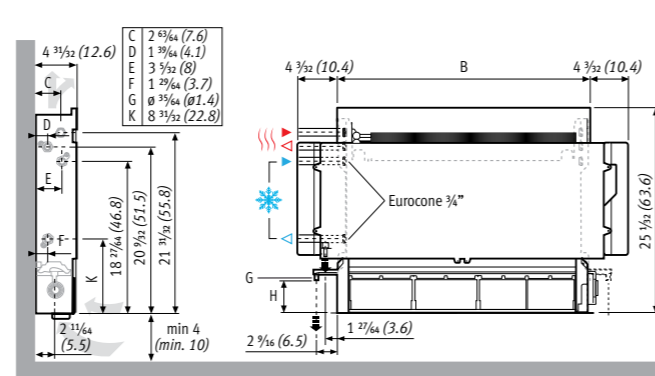
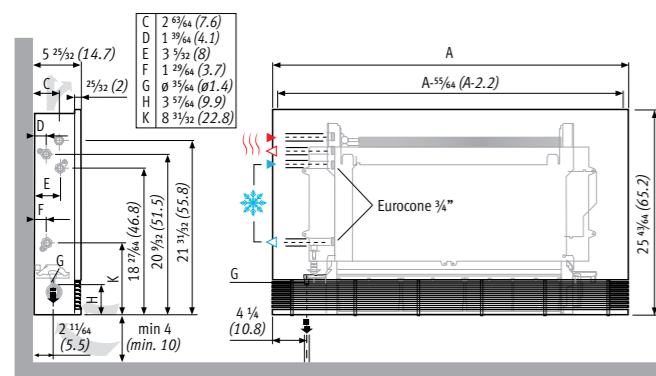

Jaga Canada Climate Systems Inc. - J204-155 Frobisher Drive
Waterloo, Ontario N2V 2E1 - info@jaga-canada.com - www.jaga-canada.com



www.
THE RADIATOR FACTORY
.COM
www.JAGAEXPERIENCELAB.COM

27200.???????? - 0311 - JAGA N.V.



jagaHybridHeating

BRIZA

ULTRA-SLENDER, SUPER-POWERFUL

The power behind the Briza comfort system is the ingenious Low-H₂O technology, combined with a silent dynamic system. Briza is the slimmest type with such power available on the market. It's like putting the power of a Jaga Ventilò in a slender design radiator. That also makes Briza ideal for connecting to low-temperature systems like heat pumps, solar energy systems and condensing boilers.



WARM IN THE WINTER, COOL IN THE SUMMER

Briza is a climate unit with a dual personality. It is a hybrid that provides comfortable heat in the winter and refreshing coolness in the summer. You get the ideal indoor climate at every moment of the year.

Briza has a sophisticated Low-H₂O heat exchanger. It has a much lower water volume than traditional radiators. An ingenious technology with a wide range of benefits, such as its already-legendary economy. The combination with the dynamic system gives the Briza even more power. The unit can therefore distribute the warmth over the whole area more quickly.

Just as Briza provides warmth in the winter, it provides cooling in the summer. Don't let its slender figure mislead you. This unit has the power of an air-conditioning system, and a lot of added benefits, too. Air-conditioning systems can sometimes give you the chills. Not Briza. Briza efficiently spreads the desired amount of freshness through the room and sets the right feeling temperature.

GIVING AND TAKING

Jaga is a pioneer in the cradle-to-cradle philosophy. We accept without reservation the challenge of producing as little waste as possible. By making products that are sustainable, by using renewable materials and by returning as much of the energy that we use back to the source.

By doing it that way, the Briza, in combination with a heat pump, achieves maximum heat recovery. During the winter, Briza heats your home with heat pumped up from the soil. In the summer, the same system returns the heat to the earth, while ensuring that the house is cool. The circle is thus complete.

Briza: heating and cooling with no loss of comfort and attention for the environment.

