



Briza 22

Powerful ECM fan coil

Positioning	Wall, Ceiling, Built-in, Freestanding
Heating capacity	Up to 150 MBH
Cooling capacity	Up to 4 tons
Airflow	Up to 1779 CFM
Depth	8 ¾" (22 cm)



jaga CLIMATE DESIGNERS

GENERAL

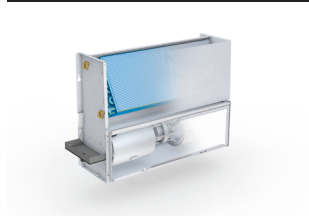

BUILT-IN



CASING



BUILT-IN HP



OPTIONS



Introduction **3**

About Briza 22 4

Main parts **5**

Range **6**

Nomenclature **9**

General technical data

General technical data 10

Coil 12

Centrifugal fan 19

Fan curves 21

Product specifications 27

Built- in wall

Configuration 31

Dimensions 35

Built- in ceiling

Configurations 37

Dimensions 40

Technical data

2-pipe performance 42

4-pipe performance 44

Air filtration **46**

Wall mounted

Configuration 48

Dimensions 51

Ceiling mounted

Configuration 52

Dimensions 54

Freestanding

Configuration 55

Dimensions 57

Technical data

2-pipe performance 58

4-pipe performance 60

Air filtration **62**

Built-in HP

Configuration 64

Dimensions 67

Technical data

2-pipe performance 68

4-pipe performance 70

Air filtration **72**

Electric heater **74**

Air mixing box **77**

Condensate overflow switch **80**

90° angle piece **81**

Grille **85**

Plenum connections **86**

Integrated on/off fan controller **88**

Spare parts **90**

Introduction

At just 8 ¾" deep, the Briza is the ultimate hydronic fan coil for quiet, space-saving heating and cooling. Tucked into the wall or ceiling in ducted or nonducted installation, Briza 22 includes a high-quality aluminum-copper dynamic coil with hydrophilic coating. Powered by an EC Motor for less energy consumption, it produces less noise and has a longer lifetime than most other fan coils available! A non-ducted Briza 22 can cover up to 27' of horizontal air throw and remain under 35dBA.

Briza 22 is easy to install and ideal for non-ducted or ducted installations as a space saving solution. Use the compact Briza 22 fan coil in the ceiling and its space-saving design can allow for the addition of another floor within a given building height.

Briza can easily handle up to 0.4" of external static pressure for ducted installations.

Ventilation with Briza 22 is also possible with addition of the air mixing box.

Features



EC MOTOR TECHNOLOGY

for less electrical energy consumption



LOW NOISE LEVEL

with up to 27' of horizontal air throw at under 35dBA



COMPACT DESIGN

the slimmest fan coil on the market available in 5 lengths



VERSATILE CONNECTIONS

available in a 2- and 4-pipe system and various supply and return options



0...10V CONTROL

enables modulating control, using the latest home automation and building management systems



WHISPER QUIET

due to the balanced, isolated, EC motor/blower

About Briza 22

Jaga Briza 22 is suitable for renovation projects, climate control of homes, shops, office spaces, school buildings, hotels and meeting rooms. It can be connected to an air to water heat pump to provide powerful, economic heating and cooling anytime of year.

- 0-10V interface solution for Building Management Systems (BMS)
- Heating and /or cooling
- High-quality, aluminum-copper, dynamic coil with hydrophilic
- Built-in to wall or ceiling
- Available in 6 lengths
- 2-pipe or 4-pipe-system
- Easy installation
- Various supply and return air options
- Low noise level
- EC-motor for standard or ducted (HP) applications
- Optional integrated on/off fan controller

Jaga N.V. uses the exclusive GreenTech EC technology of EBM-PAPST.

Jaga N.V. uses the exclusive GreenTech EC technology of EBM PAPST. Permanent magnet BLDC motor with inverter integrated in the fan assembly, protection rating IP44, insulation class F and ball bearings. BLDC motors directly integrated with the fan assembly and inverter and 32% reductions in electricity consumption compared to traditional AC motors. Polypropylene (PP) housing. Centrifugal fan with forward-curving blades made of glass-filled polyamide PA 6.

Conformity with 2017 ErP Directive.

EC Greentech EBM-PAPST motor: faster, more powerful, more economical, more sustainable

EC technology: intelligent, low-energy use and eco-friendly. EC motors cut operating costs, reduce the impact on the environment and impress with their quiet operation.

With the introduction of the electronic commutation or EC motors, we take the next step into the direction of low-energy consumption, less noise and a longer lifetime.



Main parts

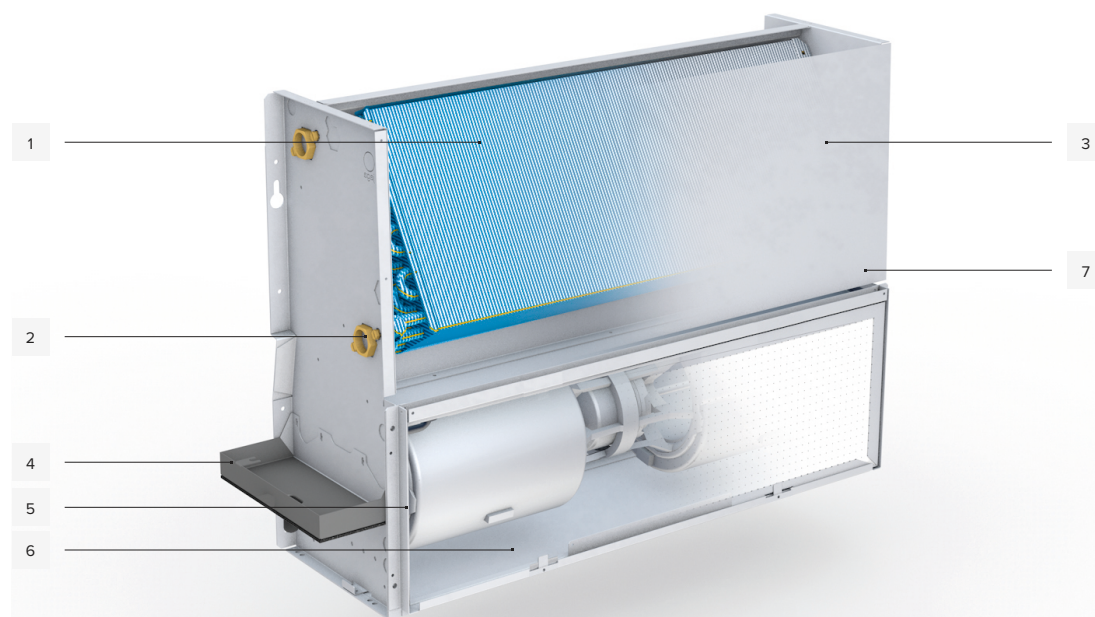

- 1 Aluminum-copper coil with hydrophilic coating
- 2 Hydraulic connection: $\frac{3}{4}$ " standard left
- 3 Internal frame in reinforced galvanized steel
- 4 Condensate drain, connection $\frac{3}{4}$ "
- 5 Centrifugal fan(s) with double inlet
- 6 Replaceable 1, 2 or 4" MERV 8 or 13 filter
- 7 Electrical connection, standard right*

*Same side upon request.

Range

Briza 22 built-in wall:

- 4 versions, each in 6 lengths
- 2-pipe system or 4-pipe system

Types:

T2 / 55 , T3 / 75 , T4 / 95 , T6 / 125 , T8 / 155 , T10 / 190

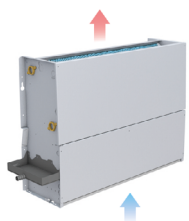

TYPE BABW/BT

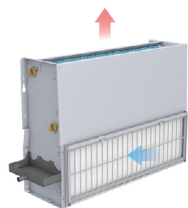

TYPE BABW/FT

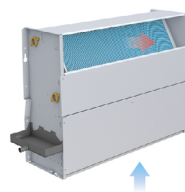

TYPE BABW/BF

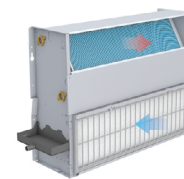

TYPE BABW/FF

Briza 22 built-in ceiling:

- 2 versions, each in 6 lengths
- 2-pipe system or 4-pipe system

Types:

T2 / 55 , T3 / 75 , T4 / 95 , T6 / 125 , T8 / 155 , T10 / 190

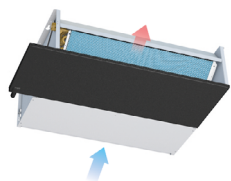

TYPE BABC/BT

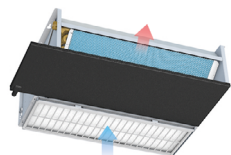

TYPE BABC/FT

Briza 22 wall mounted with casing:

- 4 versions, each in 6 lengths
- 2-pipe system or 4-pipe system

Types:

T2 / 55 , T3 / 75 , T4 / 95 , T6 / 125 , T8 / 155 , T10 / 190

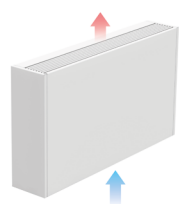

TYPE BAMW/BT

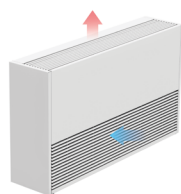

TYPE BAMW/FT

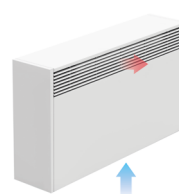

TYPE BAMW/BF

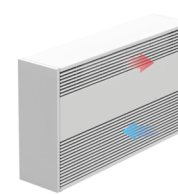

TYPE BAMW/FF

Briza 22 ceiling mounted with casing:

- 2 versions, each in 6 lengths
- 2-pipe system or 4-pipe system

Types:

T2 / 55 , T3 / 75 , T4 / 95 , T6 / 125 , T8 / 155 , T10 / 190



TYPE BAMC/BT

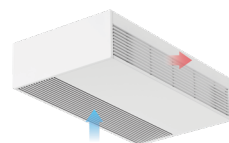

TYPE BAMC/FT

Briza 22 freestanding:

- 1 version, each in 6 lengths
- 2-pipe system or 4-pipe system

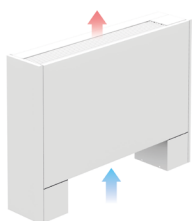

TYPE BAMF/BT

Types:

T2 / 55 , T3 / 75 , T4 / 95 , T6 / 125 , T8 / 155 , T10 / 190

Briza 22 HP built-in ceiling

High Performance:

- High-performance centrifugal fan(s) with double inlet

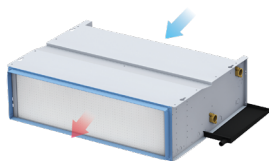

TYPE BPBC/BT

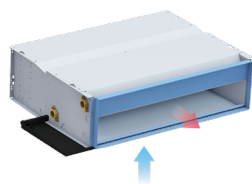

TYPE BPBC/FT

Types:

T3 / 75 , T4 / 95 , T6 / 125 , T8 / 155 , T10 / 190

Nomenclature

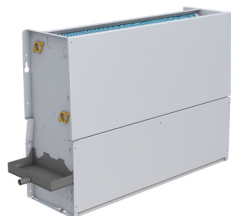

TYPE: BABW/**BT**



TYPE: BABW/**FT**

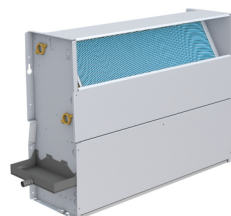

TYPE: BABW/**BF**



TYPE: BABW/**FF**

Built-in

BAB-.055 XXX22/YY/ZZ

- = C for ceiling or W for wall
- XXX = Length (cm)
- YY = Configuration: BT/FT/BF/FF
- ZZ = 20 for 2-pipe/40 for 4-pipe

Casing

BAM-.062XXX22/YY/ZZ

- = C for ceiling or W for wall
- XXX = Length (cm)
- YY = Configuration: BT/FT/BF/FF
- ZZ = 20 for 2-pipe/40 for 4-pipe

Built-in optional high performance

BAB-*.055 XXX22/YY/ZZ

- = C for ceiling or W for wall
- XXX = Length (cm)
- YY = Configuration: BT/FT/BF/FF
- ZZ = 20 for 2-pipe/40 for 4-pipe

Casing

BAM-.062XXX22/YY/ZZ(HP)

- = C for ceiling or W for wall
- XXX = Length (cm)
- YY = Configuration: BT/FT/BF/FF
- ZZ = 20 for 2-pipe/40 for 4-pipe

*BPB for HP



General technical data

MODEL		T2 / 55	T3 / 75	T4 / 95	T6 / 125	T8 / 155	T10 / 190
Electrical connection	V-PH -Hz	120-1-60	120-1-60	120-1-60	120-1-60	120-1-60	120-1-60
Length	cm	55	75	95	125	155	190
	inch	21 5/8"	29 1/2"	37 3/8"	49 3/16"	61"	74 7/8"
Height	cm	54.5	54.5	54.5	54.5	54.5	54.5
	inch	3 7/8"	3 7/8"	3 7/8"	3 7/8"	3 7/8"	3 7/8"
Depth	cm	22.2	22.2	22.2	22.2	22.2	22.2
	inch	8 3/4"	8 3/4"	8 3/4"	8 3/4"	8 3/4"	8 3/4"
Weight	kg	17	21.5	27	35.5	44	56
	LBS	37.5	47.4	59.5	78.3	97	123.5
Connection primary coil	inch	3/4" NPT (F)	3/4" NPT (F)	3/4" NPT (F)	3/4" NPT (F)	3/4" NPT (F)	3/4" NPT (F)
Connection secondary coil	inch	1/2" NPT (F)	1/2" NPT (F)	1/2" NPT (F)	1/2" NPT (F)	1/2" NPT (F)	1/2" NPT (F)
Connection condensate drain	mm	20	20	20	20	20	20
	inch	3/4"	3/4"	3/4"	3/4"	3/4"	3/4"
Coil type (primary)		4 rows	4 rows	4 rows	4 rows	4 rows	4 rows
Water capacity primary coil	L	1.23	1.77	2.23	3.14	4.05	4.46
	gallon	0.32	0.47	0.59	0.83	1.07	1.18
Water capacity secondary coil	L	0.31	0.42	0.53	0.69	0.85	1.06
	gallon	0.08	0.11	0.14	0.18	0.22	0.28
Number of fans		1	2	2	3	4	5



MODEL		T2 / 55	T3 / 75	T4 / 95	T6 / 125	T8 / 155	T10 / 190
		W	W	W	W	W	W
Electrical power (Pe)	2 VDC	3.7	3.6	4	9	6.3	11.1
	4 VDC	8	8.5	10	18	15	25.9
	6 VDC	17	18	20	34	35	52
	8 VDC	29	31	36	59	64	93
	10 VDC	42	45	50	79	86	131
		A	A	A	A	A	A
Current (I)	2 VDC	0.36	0.41	0.44	0.64	0.73	1
	4 VDC	0.26	0.29	0.33	0.48	0.55	0.77
	6 VDC	0.16	0.17	0.19	0.31	0.31	0.47
	8 VDC	0.09	0.09	0.1	0.19	0.15	0.26
	10 VDC	0.06	0.05	0.05	0.12	0.08	0.15
	inH₂O	CFM	CFM	CFM	CFM	CFM	CFM
Air flow (CFM) in function of static pressure (inH₂O) @10 V speed	0	285.46	350.2	449.67	649.79	745.14	1131.25
	0.04	264.86	323.72	406.12	591.52	679.81	1047.67
	0.08	250.15	306.06	376.69	559.15	632.72	959.38
	0.121	235.43	282.52	347.26	523.83	585.63	869.92
	0.161	223.66	264.86	323.72	488.52	538.55	781.04
	0.201	206	241.32	291.35	453.2	488.52	693.93
	0.241	194.23	220.72	258.97	414.95	444.38	606.82
	0.281	176.57	197.17	226.6	373.75	397.29	519.13
	0.321	155.97	170.69	197.17	326.66	344.32	427.9
	0.362	141.26	141.26	161.86	279.57	282.52	329.01
	0.402	117.72	114.77	129.49	223.66	220.72	217.19
	0.442	100.06	82.4	88.29	179.52	161.86	86.52
0.482	82.4	50.03	52.97	129.49	94.17	-	
	inH₂O	W/CFM	W/CFM	W/CFM	W/CFM	W/CFM	W/CFM
Specific power @10 V speed with MERV 4	0	0.667	0.576	0.498	0.545	0.517	0.519
	0.12	0.593	0.568	0.509	0.572	0.511	0.678

BRIZA 22

GENERAL TECHNICAL DATA

Briza 22 primary coil

High-quality coil for heating and cooling

The coil consists of 4 rows of round seamless tubes made of pure red copper, connected to aluminum fins with a hydrophilic coating. It includes an integrated hydraulic header, including an air vent. Connection $\frac{3}{4}$ " NPT left, also available with righthand side connection.

- Heating and cooling coil in 2-pipe configuration
- Cooling coil in 4-pipe configuration

2-pipe system:

- A 2-pipe fan coil system consists fan coil units with a single coil connected to two pipes (one supply pipe and one return pipe). A building with a 2-pipe system is either entirely in heating mode or entirely in cooling mode.

4-pipe system:

- A 4-pipe system consists of fan coil units with a separate heating and cooling coil, as well as separate pairs of heating and cooling pipes. Hot water and chilled water is always available.

The system is able to instantly switch from heating to cooling mode, or vice versa, and can provide heating to some rooms while simultaneously cooling other rooms.

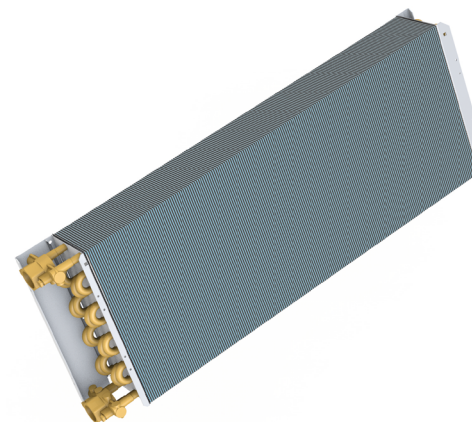



Pressure drop curve standard coil

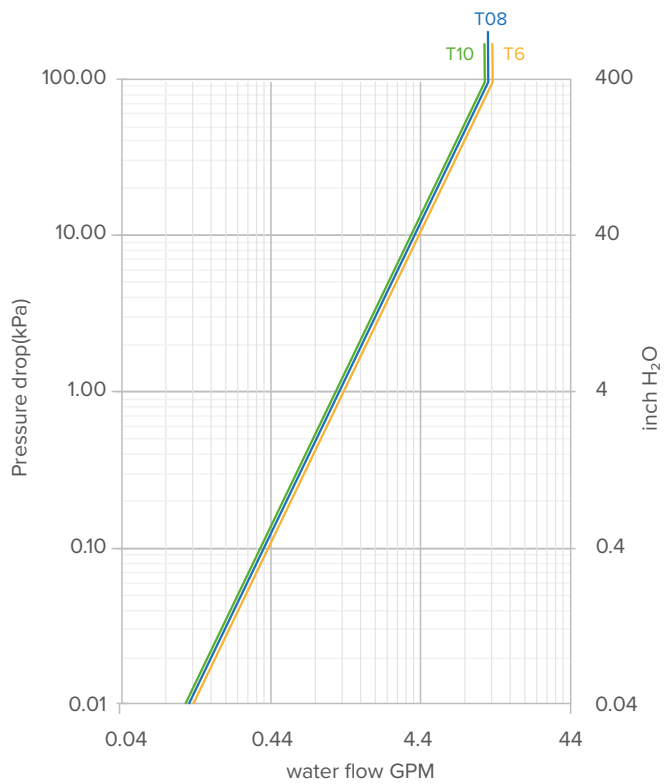
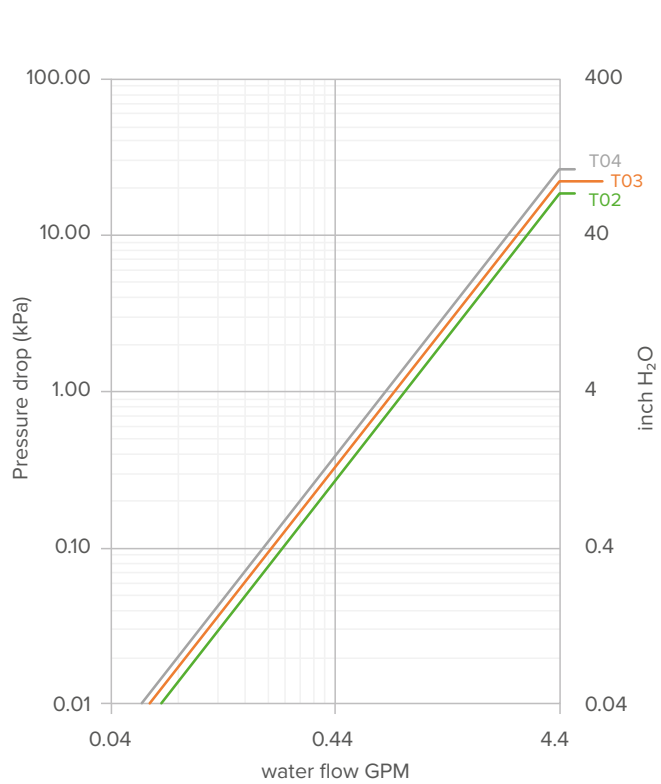

BRIZA 22

GENERAL TECHNICAL DATA

DIMENSIONS

Dimensions T2 / T3 / T4

- In a 2-pipe system for heating and cooling
- In a 4-pipe system for cooling

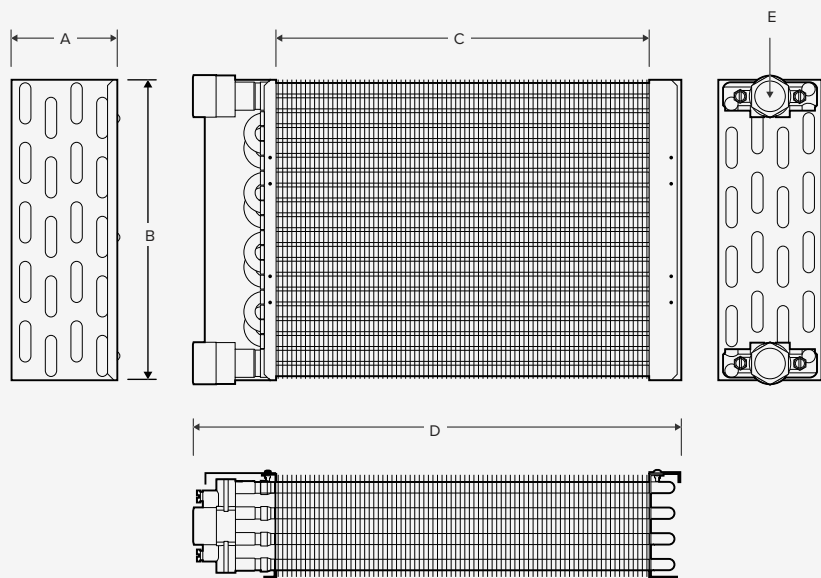

	A	B	C	D	E
L (inches)	3 1/2"	9 5/8"	L - 5 1/2"	L - 1 3/4"	3/4"
L (cm)	8.66	25	L - 13.8	L-4.4	3/4"

Dimensions T6 / T8 / T10

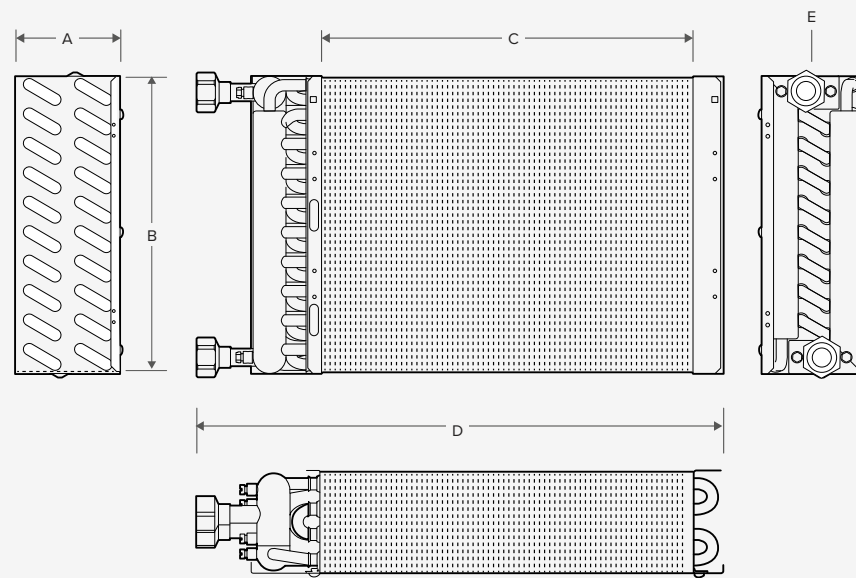

	A	B	C	D	E
L (inches)	3 1/2"	9 5/8"	L - 5 1/2"	L	3/4"
L (cm)	8.66	25	L - 13.8	L	3/4"

BRIZA 22

GENERAL TECHNICAL DATA



Technical data

MODEL			T2 / 55	T3 / 75	T4 / 95	T6 / 125	T8 / 155	T10 / 190
Coil	(± 5 mm) Length	mm	506.5	706.5	906.5	1250	1550	1900
		inch	19 ½"	27 ½"	35 ¾"	49 ⅛"	61"	74 ¾"
	(± 3 mm) Finned Length	mm	412	612	812	1112	1412	1762
		inch	16 ¼"	24 ⅛"	32"	43 ¾"	55 ½"	69 ¾"
	Header material		brass	brass	brass	brass	brass	brass
	Air vent	Qty	1	1	1	1	1	1
	Water content	litre	1.2	1.8	2.2	3.1	4.1	5.0
		gallon	0.3	0.5	0.6	0.8	1.1	1.3
	Test pressure	bar	26	26	26	26	26	26
		PSI	377	377	377	377	377	377
	Working pressure	bar	20	20	20	20	20	20
		PSI	290	290	290	290	290	290
	Connection	inch	NPT ¾"	NPT ¾"	NPT ¾"	NPT ¾"	NPT ¾"	NPT ¾"
Coating		hydrophilic coating	hydrophilic coating	hydrophilic coating	hydrophilic coating	hydrophilic coating	hydrophilic coating	
Material circulation tubes		copper	copper	copper	copper	copper	copper	
Fins	Size h x w	mm	250 x 86.6 mm	250 x 86.6 mm	250 x 86.6 mm	250 x 86.6 mm	250 x 86.6 mm	250 x 86.6 mm
		inch	9 ⅞" x 3 ½"	9 ⅞" x 3 ½"	9 ⅞" x 3 ½"	9 ⅞" x 3 ½"	9 ⅞" x 3 ½"	9 ⅞" x 3 ½"
	Size	cm ²	216.5	216.5	216.5	216.5	216.5	216.5
		inch ²	33.6	33.6	33.6	33.6	33.6	33.6
	Spacing	mm	2.1	2.1	2.1	2.1	2.1	2.1
		inch	⅛"	⅛"	⅛"	⅛"	⅛"	⅛"
Material		aluminium	aluminium	aluminium	aluminium	aluminium	aluminium	

*In a two-pipe system for heating and cooling
In a 4-pipe system for cooling*

Briza 22 secondary coil

High-quality coil for heating in a 4-pipe system. The coil consists of one row of round seamless pipes made of pure red copper, connected to aluminum fins with a hydrophilic coating. It includes an integrated hydraulic header, including air vent. Connection 1/2" NPT left, also available with right hand side connection.

- Heating coil in 4-pipe configuration

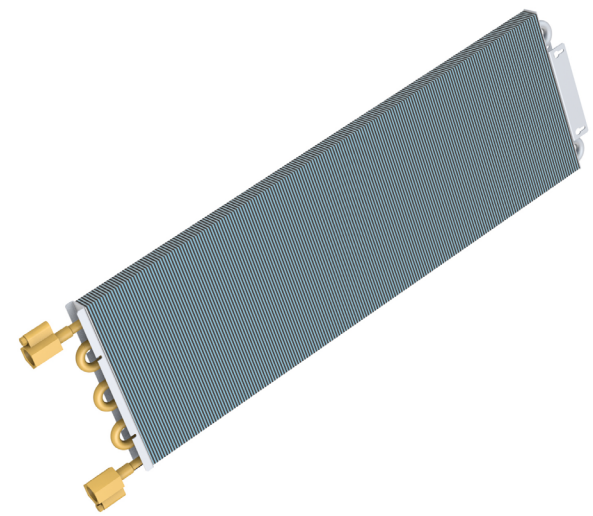

Pressure drop curve for secondary coil

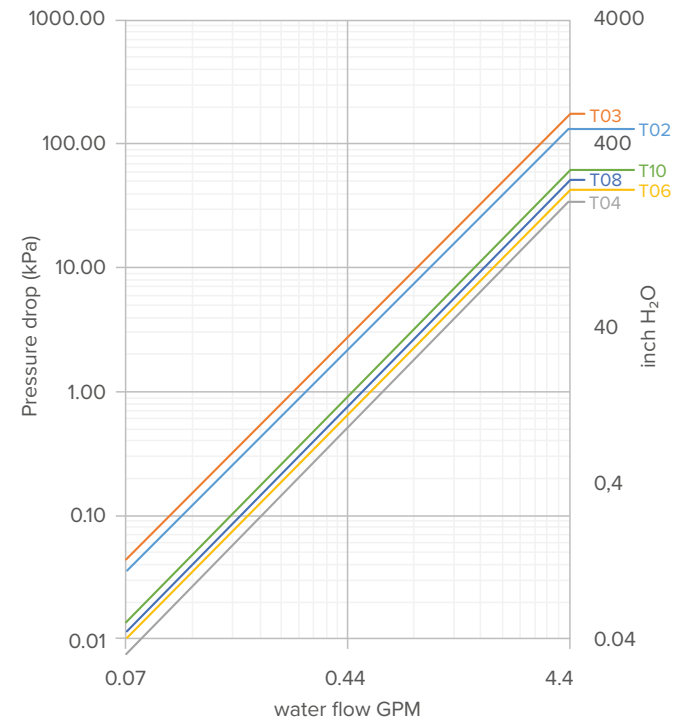

BRIZA 22

GENERAL TECHNICAL DATA

DIMENSIONS

Dimensions

- In a 4-pipe system for heating only

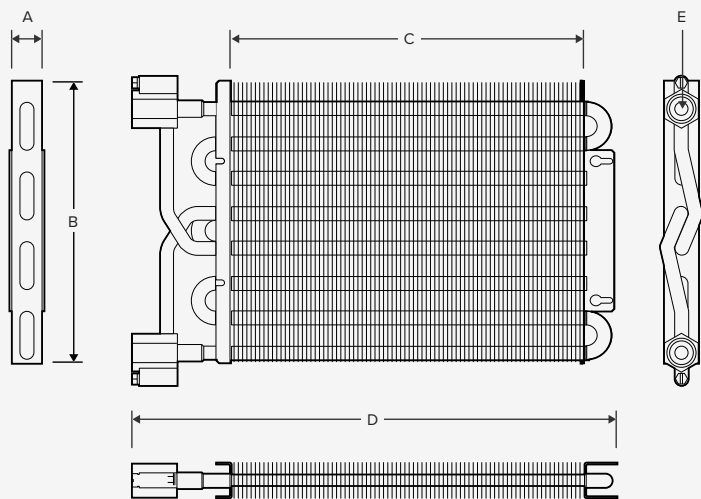

	A	B	C	D	E	F
L (inches)	8 ½"	8	L-2"	L-4"	½" NPT	½" NPT
L (cm)	21.65	20.3	L-5	L-13.8	½" NPT	½" NPT

Technical data

MODEL			T2 / 55	T3 / 75	T4 / 95	T6 / 125	T8 / 155	T10 / 190
Coil	(± 5 mm) Length	mm	545	745	845	1245	1545	1945
		inch	21 7/16"	29 5/16"	33 1/4"	49"	60 13/16"	76 9/16"
	(± 3 mm) Finned Length	mm	512	712	812	1112	1412	1812
		inch	20 3/16"	28 1/16"	31 15/16"	43 3/4"	55 9/16"	71 5/16"
	Material collector		brass	brass	brass	brass	brass	brass
	Air vent	number	1	1	1	1	1	1
	Water content	litre	0.31	0.42	0.53	0.69	0.85	1.01
	Pressure test element	bar	26	26	26	26	26	26
	Workload max.	bar	20	20	20	20	20	20
	Connection	inch	1/2" NPT	1/2" NPT	1/2" NPT	1/2" NPT	1/2" NPT	1/2" NPT
	Coating		hydrophilic coating	hydrophilic coating	hydrophilic coating	hydrophilic coating	hydrophilic coating	hydrophilic coating
	Type coil		1 row	1 row	1 row	1 row	1 row	1 row
	Material circulation tubes		copper	copper	copper	copper	copper	copper
Fins	Size hwx	mm	203 x 21.65	203 x 21.65	203 x 21.65	203 x 21.65	203 x 21.65	203 x 21.65
	Size	cm ²	439.5	439.5	439.5	439.5	439.5	439.5
	Spacing	mm	2.1	2.1	2.1	2.1	2.1	2.1
	Material		aluminium	aluminium	aluminium	aluminium	aluminium	aluminium

In a 4-pipe system for heating only

Centrifugal fan

Nominal data:

- Phase: 1~
- Nominal voltage: 115 VAC (200-240VAC)*
- Frequency: 60 Hz
- Type of data definition: ml
- Speed: RPM 910 (1120)*
- Max. power: input 60 W (170 W)*
- Current draw: 0.5 A (0.8 A)*
- Min. static pressure: 0 Pa
- Min. ambient temperature: -13 °F
- Max. ambient temperature: 122 °F

*For Briza 22 HP

GREEN-TECH fan(s):

- Surface of rotor: galvanised
- Material of electronics housing: black PP plastic
- Material of impeller: PA plastic
- Housing material: black PP plastic
- Motor suspension: anti-vibration suspension, mounted on both sides
- Direction of rotation: clockwise, seen on rotor
- Type of protection: motor IP 44, electronic IP 20
- Insulation class: F
- Max. permissible ambient motor temp. (transp./storage) + 26 °F
- Min. permissible ambient motor temp. (transp./storage) - 40 °F
- Motor bearing: ball bearing

Technical features:

Output 10 VDC, max. 1.1 mA

- Tach output
- Motor current limit
- Soft start
- Control input 0-10 VDC/PWM
- Over-temperature protected motor

Safety

EMC interference immunity: acc. to EN 61000-6-2 (industrial environment)

EMC harmonics: acc. to EN 61000-3-2/3

EMC interference emission: acc. to EN 61000-6-3 (household environment)

Touch current: acc. IEC 60990 (measuring network Fig. 4, TN system)

<= 3.5 mA

Motor protection: thermal overload protector (TOP) wired internally

Protection: class I (if protective earth is connected by customer)

Product conforming to standard: EN 60335-1

Approval: CCC



Number of fan units

Fan range					
T2 / 55*	T3 / 75	T4 / 95	T6 / 125	T8 / 155	T10 / 190
1 impeller 1 motor	2 impellers 1 motor	2 impellers 1 motor	2 impellers 2 motors	4 impellers 2 motors	5 impellers 3 motors

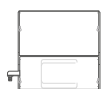

*T2 is not available as HP model.



Fan performance curves T02 L55

Control Voltage (VDC)

- 2V
- 4V
- 6V
- 8V
- 10V

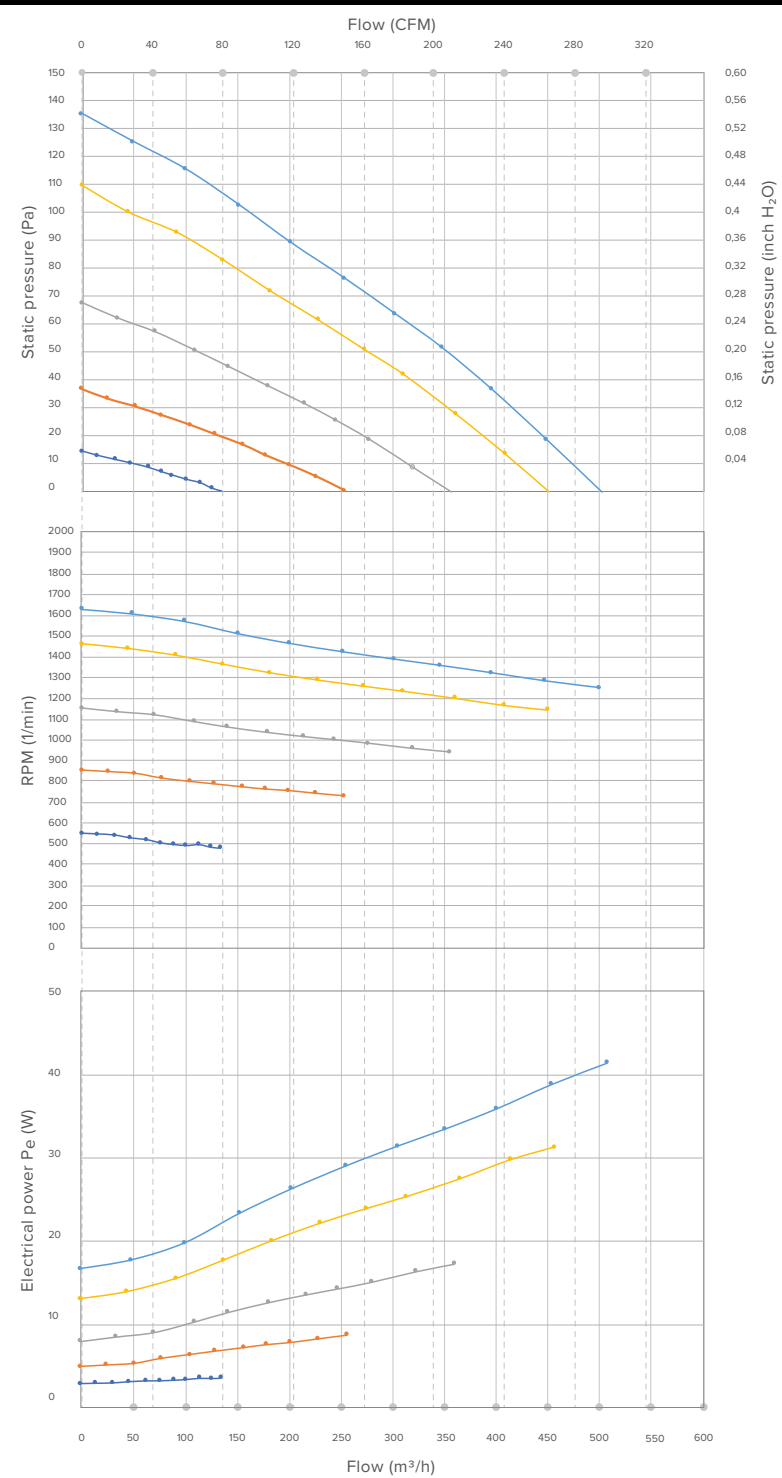



Fan performance curves T03 L75

Control Voltage (VDC)

- 2V
- 4V
- 6V
- 8V
- 10V

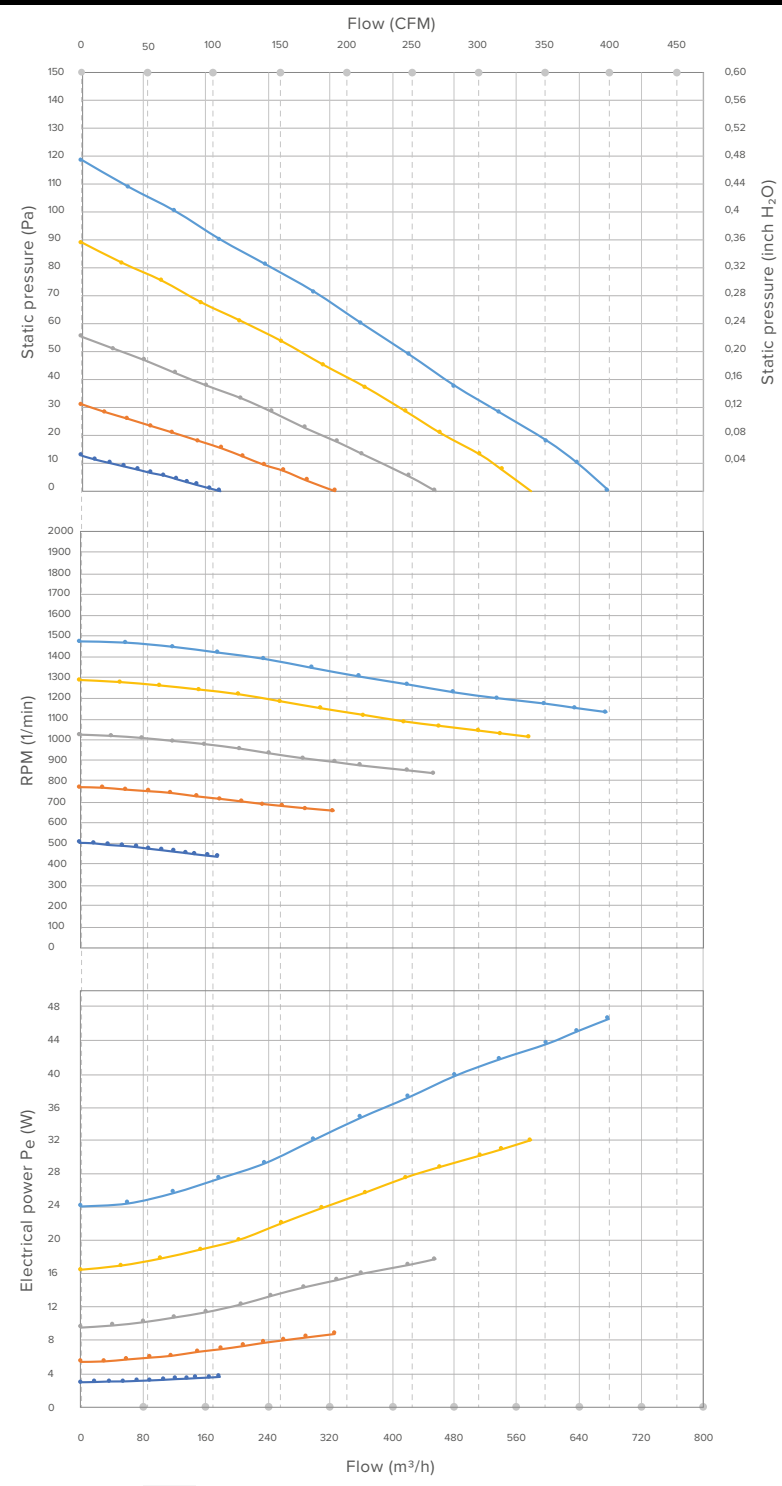



Fan performance curves T04 L95

Control Voltage (VDC)

- 2V
- 4V
- 6V
- 8V
- 10V

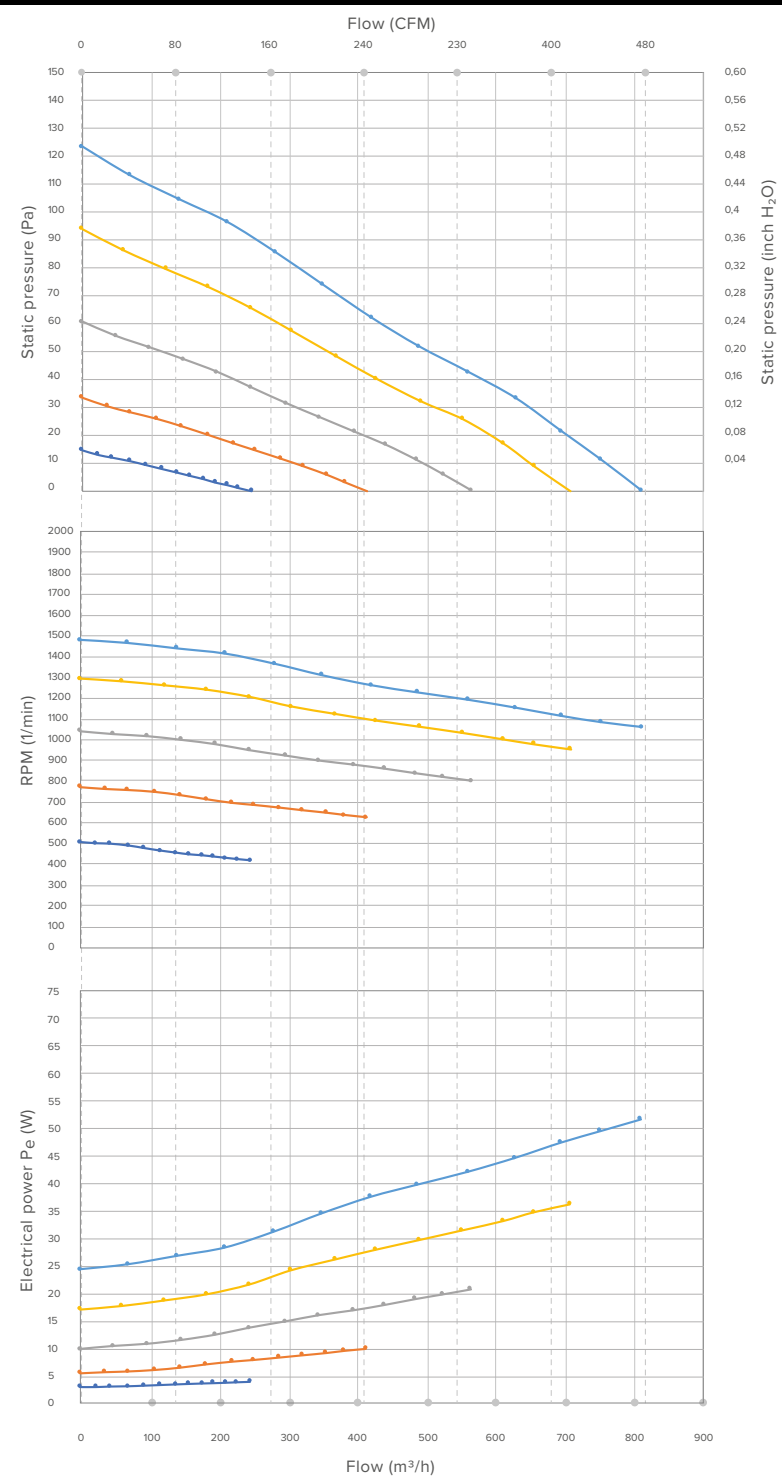



Fan performance curves T06 L125

Control Voltage (VDC)

- 2V
- 4V
- 6V
- 8V
- 10V

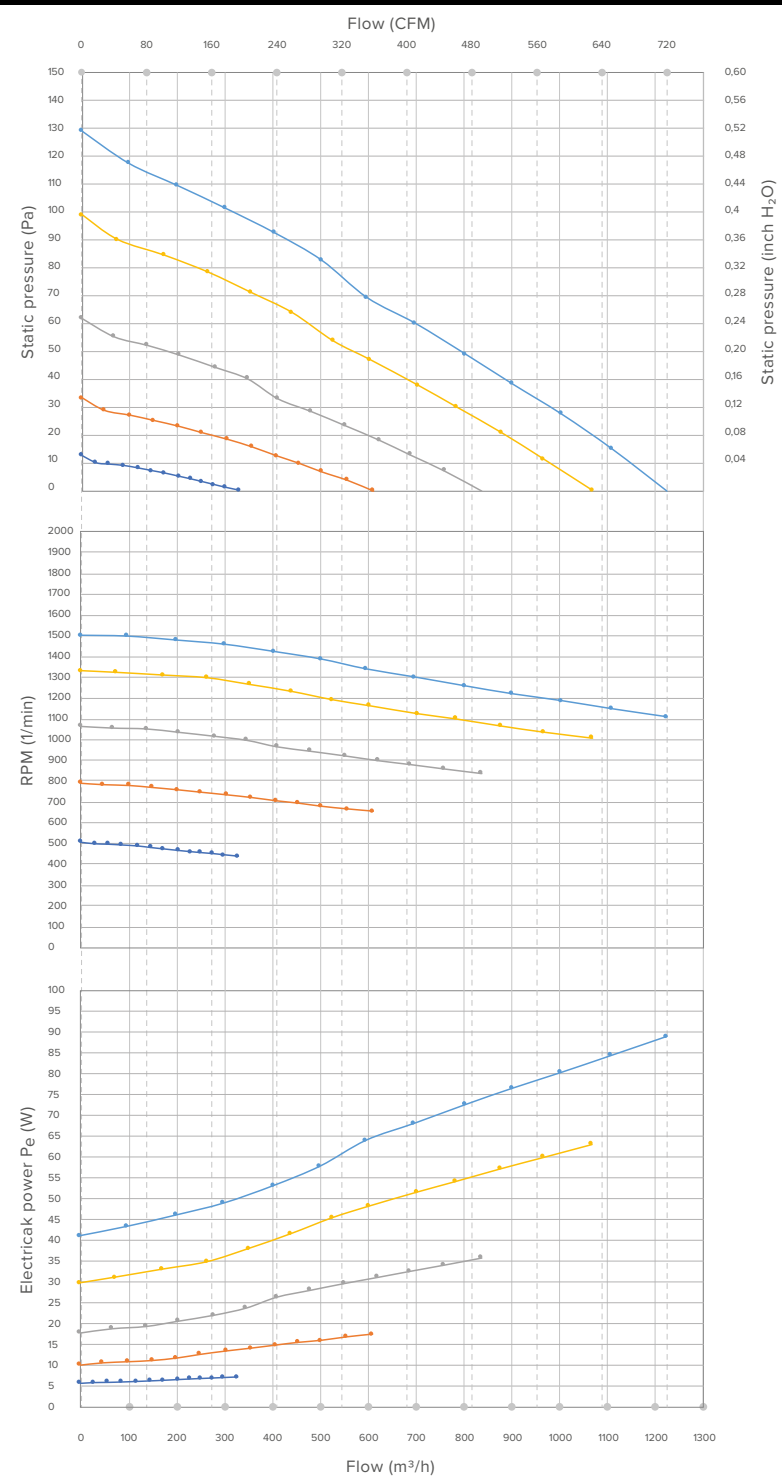



Fan performance curves T08 L155

Control Voltage (VDC)

- 2V
- 4V
- 6V
- 8V
- 10V

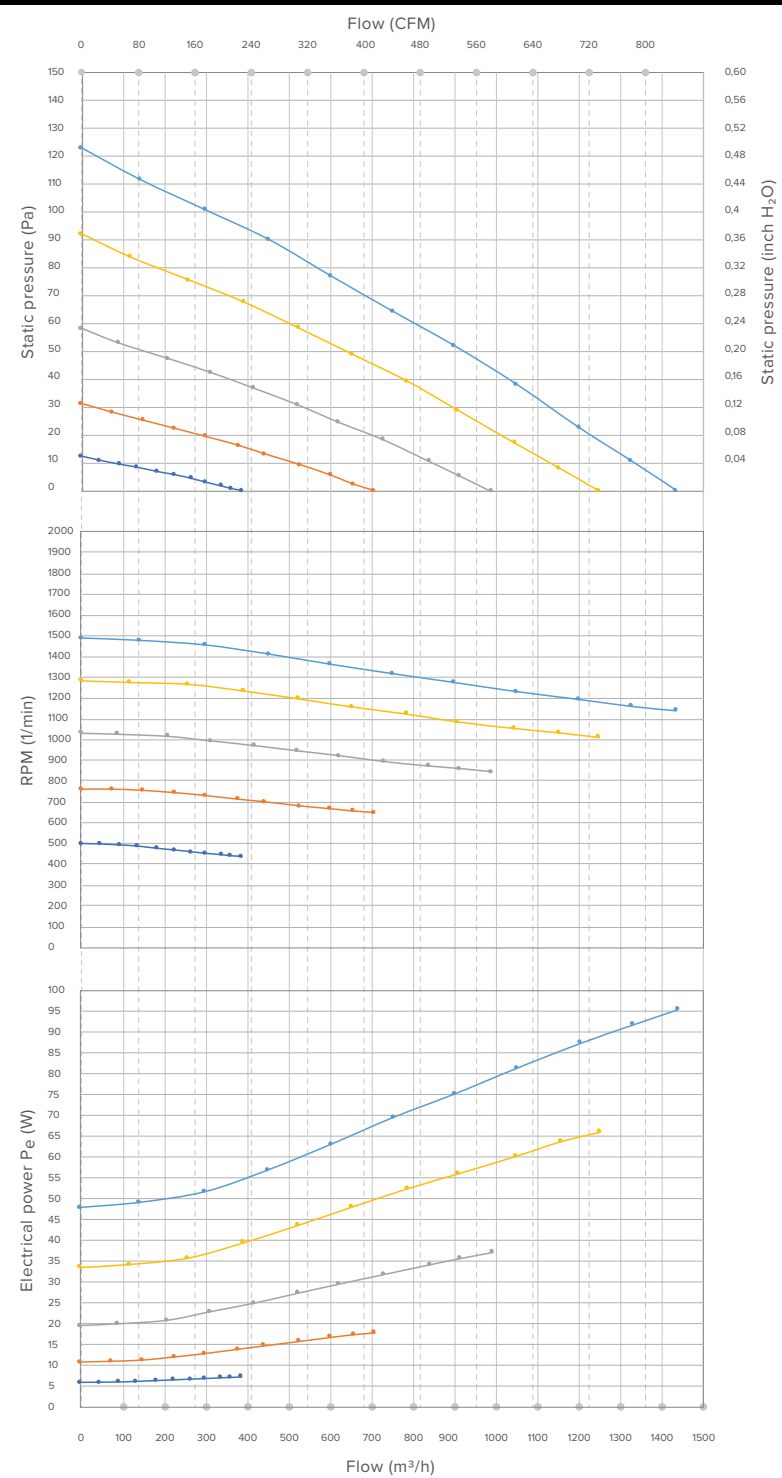



Fan performance curves T10 L190

Control Voltage (VDC)

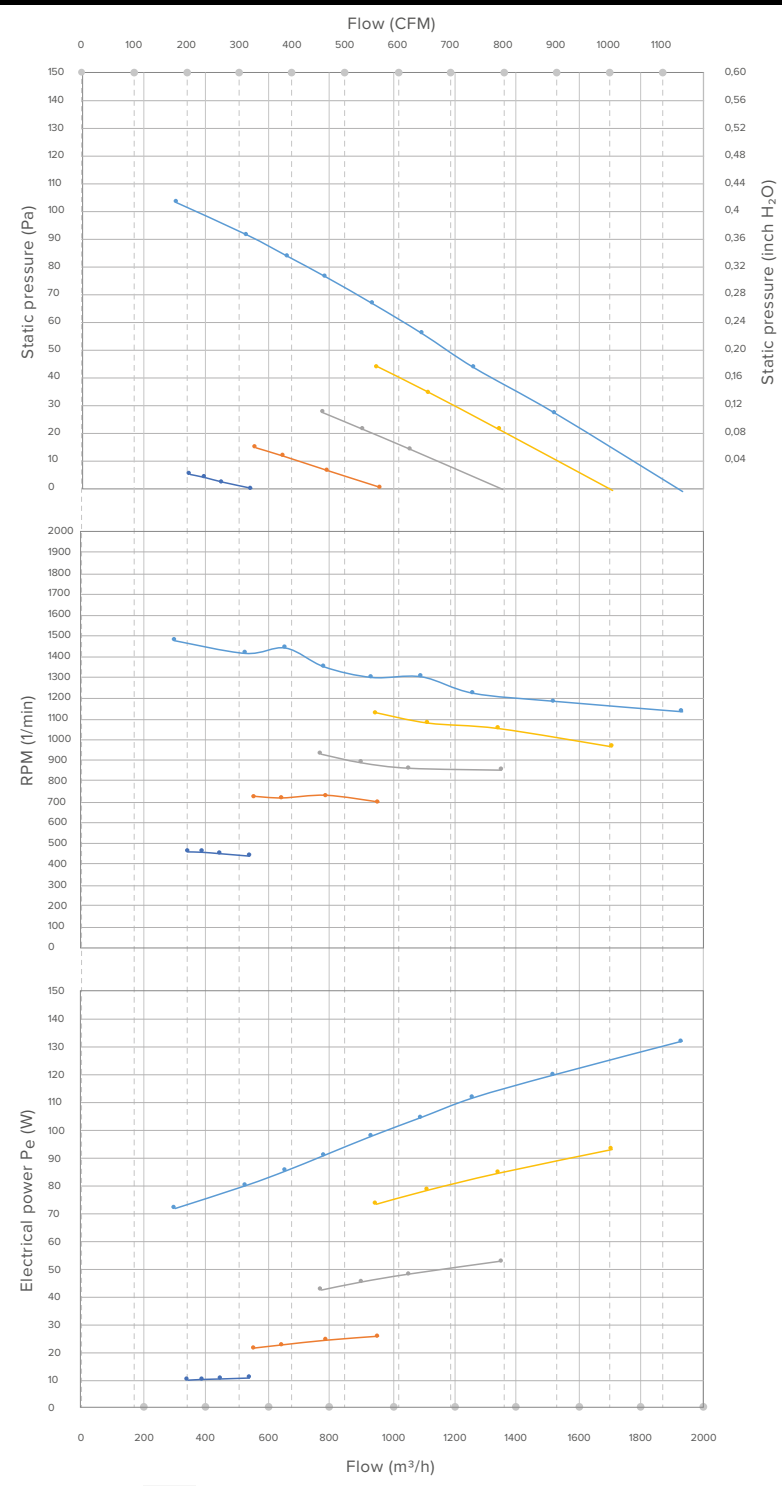

- 2V
- 4V
- 6V
- 8V
- 10V



Product specifications

Pre-mounted air conditioning unit, the same version in six models for installation in wall or ceiling, freestanding, recessed or exposed with cabinet.

Versions: 2-pipe or 4-pipe connection.

-  **Heating:** Standard equipped for connection to traditional boiler or heat pump.
-  **Cooling:** Standard equipped for connection to chilled water supply (chiller or heat pump).
-  **Ventilation:** Connecting to mechanical ventilation (via ductwork, if desired on return side) or directly connected to outside air via an air mixing box.

Internal frame:

The internal frame consists of a reinforced galvanized steel plate (18ga) and a condensate drain pan (for vertical and horizontal installation) with gravity drainage, complete with self-extinguishing, anti-condensation insulation on the side, back and front panels of the unit. Internal frame to be no deeper than 220 mm (8.7").

Exposed casing:

- The casing shall be fabricated with 18 gauge electrolytic galvanized steel and will be coated epoxy polyester baked at 392 °F. Available in two colors as standard white or grey metallic. Custom colors available upon request.
- The top grille shall provide supply air and bottom shall provide return.
- The casing front face shall be constructed of a single uniform piece seamless in construction.
- The casing shall be fabricated such that there are no exposed corners or gaps. All corners shall be joined to form one solid piece – gaps are not permitted.
- The casing shall be factory parts warranted for 10 years.

Coil:

High-quality aluminum - copper coil with hydrophilic coating. The coil consists of four rows seamless tubes of pure red copper, connected with pure aluminum fins and brass collectors equipped with a patented low pressure drop hydronic header.

- Rated for 217PSI working pressure.
- Easily removable for maintenance if required.
- Blue hydrophilic coating.
- The coil shall have ASTM G53 certification.
- Each fan coil configuration shall have EN442/EN16430 certification. Output correction factors will not be considered equivalent to establish output capacities.
- Includes NPT-connections. No adapters for No adapters for North American threads will be accepted.
- Rated for 217PSI working pressure.
- Easily removable for maintenance if required.
- Blue hydrophilic coating.
- The coil shall have ASTM G53 certification.



- Each fan coil configuration shall have EN442/EN16430 certification. Output correction factors will not be considered equivalent to establish output capacities.
- Includes NPT-connections. No adapters for North American threads will be accepted.

Hydronic connection:

Standard coil ¾" connection on the left. Also available with hydronic connection to the right. With an air vent, drain valve and anti-rotation lock for quick connection. Additional 2nd coil ½", connection on the left. Also available with hydronic connection to the right.

GREEN-TECH Fan unit(s) by EBM Papst:

An electronically commutated (EC motor) centrifugal fan with double intake, with static and dynamically balanced aluminum or ABS fan units. The inverter is driven by a single-phase voltage 120VAC 60Hz and is controllable via a 0-10VDC analog signal. The motor is provided with internal protection.

Electrical connection: standard to the right of the appliance. Connection terminals (grounding, 115 VAC (200-240VAC)*, 0 ... 10 V). Supply Voltage 115 VAC (200-240VAC)* / 60 Hz.

*For Briza HP

Fan operation at 5.8V allows for significant air throw with sound pressure under 35dBA, without any connection to duct work.

Filter:

Replaceable filter made of synthetic fibers (filter class MERV 4), removable from the front of the unit.

Terms of Use:

For indoor spaces. The device is not intended for installation or use in damp areas, such as laundry rooms (IEC EN 60335-2-40).

Conforms to the following guidelines:

- ETL Intertek 1995
- Provisions of the Machinery Directive 2006 / 42 / EC
- Low Voltage Directive 2014 /35 / EC
- Electromagnetic Compatibility Directive 2014 / 30 / EC

Operating limits:

- Max temperature supply water: 221° F
- Max pressure coil: 217 PSI
- Supply voltage: 115 VAC ± 10%, 60Hz
- Supply voltage: 200-240VAC, 60Hz (for Briza-22 HP)

How to install:

Free space supply and return air:

- Minimum 6" free space supply air device (bottom of device)
- Minimum 6" distance return air (top of appliance)

Options:

- Electrical heating element
- 115 VAC motorised damper: air mixing box with motorized damper with 0...10V control for outdoor air supply
- Wall ventilation grille Ø 5"
- Inlet angle piece 90°
- Exhaust angle piece 90°
- Adjustable air inlet grille for 90° angle

- Exhaust angle piece 90°
- Adjustable air inlet grille for 90° angle pieces

Built-In Ceiling:

- Inlet plenum connection with round flanges, connection Ø 8"
- Thermally insulated exhaust plenum connection with round flanges connection Ø 8"
- Condensate pump mounting bracket

Control option:

JDPC on/off controller (Jaga Dynamic Product Controller). The controller is factory installed and pre-programmed.

Manufacturer Jaga n.v. Belgium.

Type: BRIZA 22 HYBRID BUILT-IN WALL

Type: BRIZA 22 HYBRID BUILT-IN CEILING

What is sound power, sound pressure?

Sound power is the sound production of the device itself (source sound). The sound power is thus regarded as a fixed value independent of the installation situation.

Sound pressure is the perceptible sound. This depends on the installation situation and on various factors:

- Location of the device
- Environmental condition
- Distance to the measured source sound
- Reflection of the sound (depending on the size and the height of the room and the materials used)

Note: The sound power is always higher than the perceived sound pressure.

Reverberation time:

Reverberation time is the time — in seconds — that is needed to lower the sound pressure level by 60 dB after a sound source is switched off. This shows that the reverberation time in a large room will be greater than in a small room. Especially the acoustics and decoration of the room determines the reverberation time.

Sound power

Sound pressure





BRIZA 22



Built-in

Built-in wall configuration

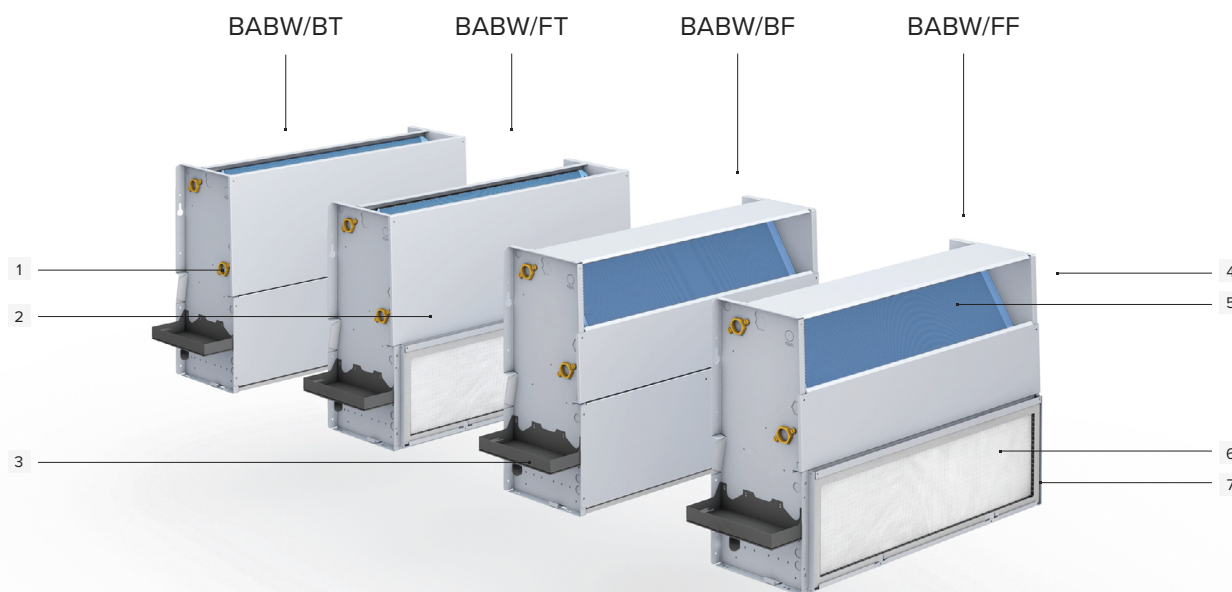

- 1 Hydraulic connection: $\frac{3}{4}$ " NPT standard left
- 2 Internal frame in reinforced galvanized steel
- 3 Condensate drain, connection $\frac{3}{4}$ "
- 4 Electrical connection, standard right*
- 5 Aluminum-copper coil with hydrophilic coating
- 6 Replaceable 1, 2 or 4" MERV 8 or 13 filter
- 7 Centrifugal fan(s) with double inlet

*Same side electrical and hydronic connections available for ceiling mounted units upon request

Built-in wall configuration

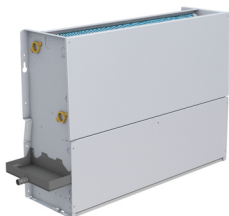

TYPE: BABW/BT

Built-In Wall standard

- Supply air at the top
- Return air at the bottom



TYPE: BABW/FT

Built-In Wall (optional)

- Supply air at the top
- Return air at the front
- Increased width for filter 3/4"

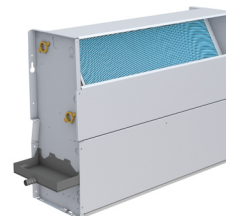
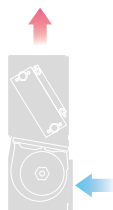

TYPE: BABW/BF

Built-In Wall (optional)

- Supply air at the front
- Return air at the bottom
- Increased width for filter 3/4"

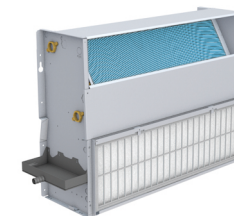

TYPE: BABW/FF

Built-In Wall (optional)

- Supply air at the front
- Return air at the front
- Increased width for filter 3/4"

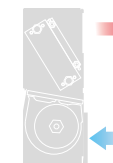

Supply/return air configurations and options

TYPE: BABW/BT

standard return air +
standard supply air



TYPE: BABW/FT

CONFIGURATION front return
air + standard supply air

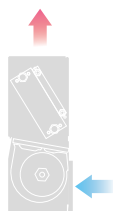

TYPE: BABW/BF

standard return air +
CONFIGURATION front
supply air



TYPE: BABW/FF

CONFIGURATION front return
air + CONFIGURATION front
supply air



OPTION air mixing box. See page 77.

0..10 V Modulating motor



OPEN

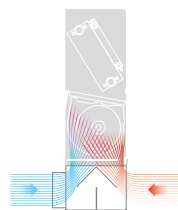

MIX

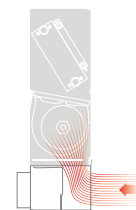

CLOSE

OPTION 90° angle piece / front inlet. See page 81.

standard return air +
OPTION 90° supply air

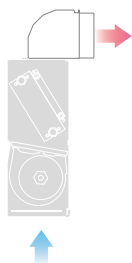

CONFIGURATION front return
air + OPTION 90° supply air

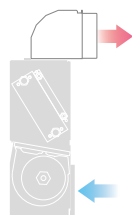

OPTION 90° angle piece. See page 82.

OPTION 90° return air +
OPTION 90° supply air

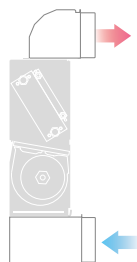

OPTION 90° return air +
CONFIGURATION front
supply air

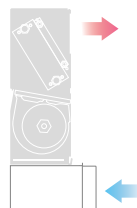

OPTION 90° return air +
standard supply air

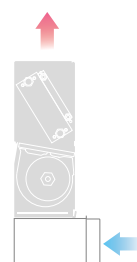

Dimensions

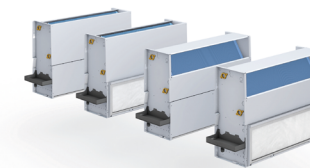

MODEL	T2 / 55	T3 / 75	T4 / 95	T6 / 125	T8 / 155	T10 / 190
Code	BABW	BABW	BABW	BABW	BABW	BABW
L (inches)	21 5/8"	29 1/2"	37 3/8"	49 1/8"	61"	72 7/8"
L (cm)	55	75	95	125	155	190



DIMENSIONS

BF / BT

FF / FT

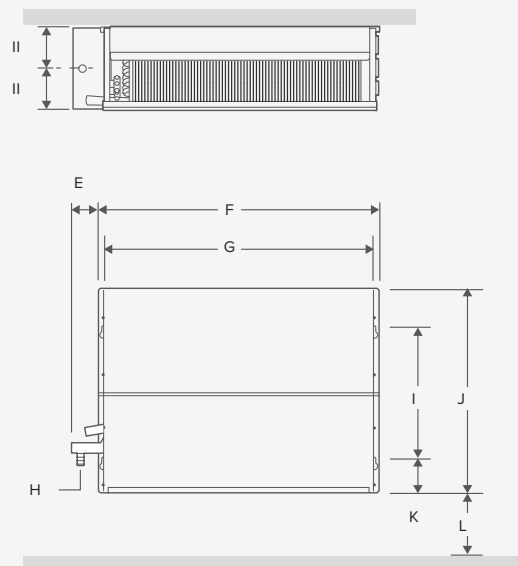

Primary coil

Secondary coil

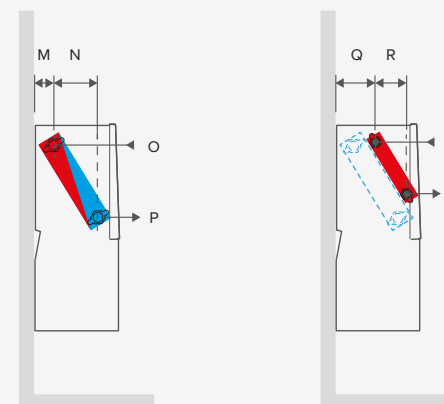

	A	B	C	D	E	F	G	H	I	J	K	L	M	N	O	P	Q	R	S	T
L (inches)	8 3/8"	8 3/4"	8 3/8"	9 1/2"	2 7/8"	L	L-1"	7/8"	13.75"	21 1/2"	3 1/2"	4"	2	4 1/2"	3/4" NPT	3/4" NPT	4 1/8"	3 1/2"	1/2" NPT	1/2" NPT
L (cm)	21.2	22.2	21.2	24.2	7.1	L	L-2.5	2	35	54.5	9	10	5	11	3/4" NPT	3/4" NPT	10.5	9	1/2" NPT	1/2" NPT

DIMENSIONS FOR INSTALLATION INTO WALL

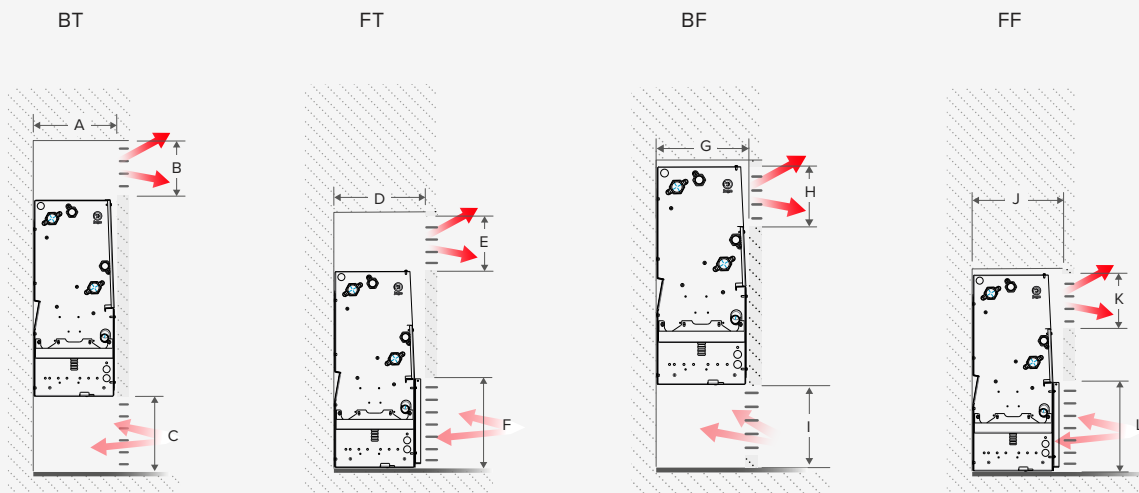

	A	B	C	D	E	F	G	H	I	J	K	L
L (inches)	≥9"	≥6"	≥6"	≥10"	≥6"	≥10"	≥9"	≥6"	≥10"	≥10"	≥6"	≥10"
L (cm)	≥22.5	≥15	≥15	≥25	≥15	≥25	≥22.5	≥15	≥25	≥25	≥15	≥25

Allow 8" for hydronic connections and 6" for electrical connections

Built-in ceiling configuration

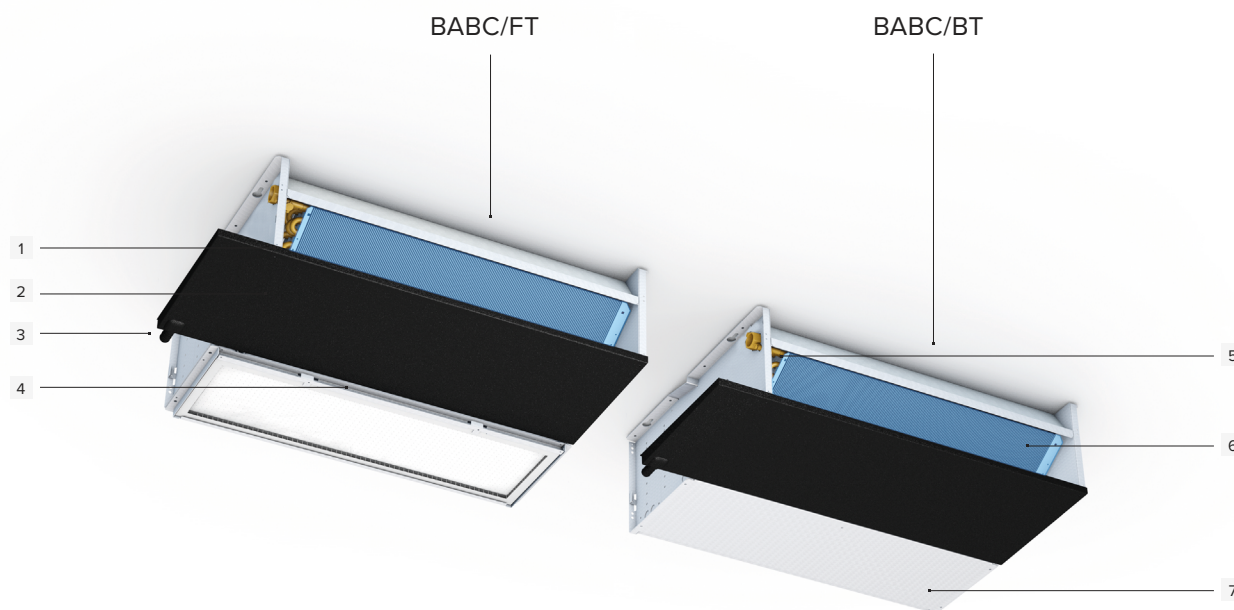

- 1 Hydraulic connection: $\frac{3}{4}$ " NPT standard left
- 2 Replaceable 1, 2 or 4" MERV 8 or 13 filter
- 3 Condensate drain, connection $\frac{3}{4}$ "
- 4 Centrifugal fan(s) with double inlet
- 5 Aluminum-copper coil with hydrophilic coating
- 6 Electrical connection, standard right*
- 7 Internal frame in reinforced galvanized steel

*Same side electrical and hydronic connections available for ceiling mounted units upon request

Built-in ceiling configuration

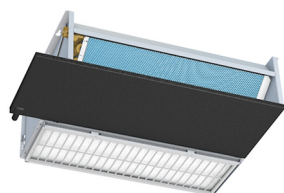
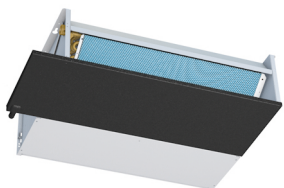

TYPE: BABC/BT

Built-In Ceiling standard

- Return air at the bottom
- Supply air at the top

TYPE: BABC/FT

Built-In Ceiling (optional)

- Return air at the front
- Supply air at the top



Supply/return air configurations and options

TYPE: BABC/BT

standard return air +
standard supply air



TYPE: BABC/FT

CONFIGURATION front return
air + standard supply air



OPTION 90° corner piece. See page 81.

standard return air +
OPTION 90° supply air



CONFIGURATION front return
air + OPTION 90° supply air

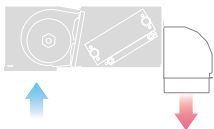

OPTION plenum connections.
See page 86.

OPTION return air +
OPTION supply air



OPTION 90° corner piece.
See page 81.

OPTION 90° return air +
OPTION 90° supply air



Dimensions

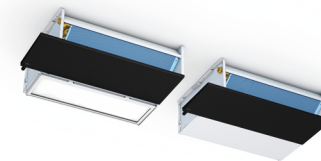

MODEL	T2 / 55	T3 / 75	T4 / 95	T6 / 125	T8 / 155	T10 / 190
Code	BABC	BABC	BABC	BABC	BABC	BABC
L (inches)	21 5/8"	29 1/2"	37 3/8"	49 1/8"	61"	72 7/8"
L (cm)	55	75	95	125	155	190



DIMENSIONS

BT / FT

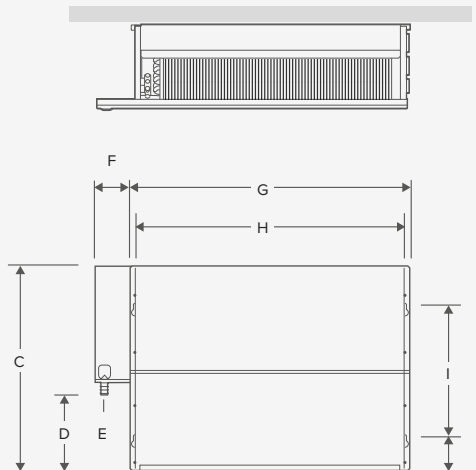

Primary coil

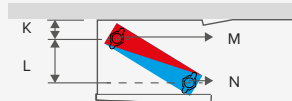

Secondary coil

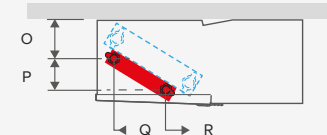

	A	B	C	D	E	F	G	H	I	J	K	L	M	N	O	P	Q	R
L (inches)	8 3/4"	9 1/8"	21 1/2"	7 7/8"	13/16"	7 9/16"	L	L-1"	13 3/4"	3 1/2"	2"	4 1/8"	3/4" NPT	3/4" NPT	4 1/8"	3 1/2"	1/2" NPT	1/2" NPT
L (cm)	22.2	23.2	54.5	20	2	19.3	L	L-2.5	35	9	5	11	3/4" NPT	3/4" NPT	10.5	9	1/2" NPT	1/2" NPT

DIMENSIONS FOR INSTALLATION INTO CEILING

BT

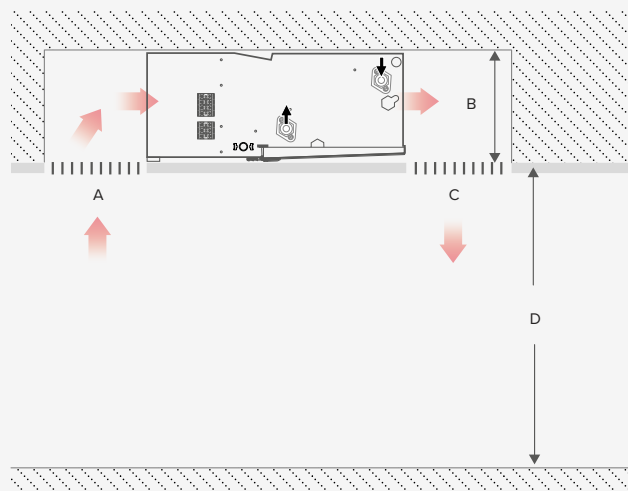

	A	B	C	D*
L (inches)	6" < > 10"	≥ 9½"	6" < > 10"	max. 10 ft
L (cm)	15 < > 25	≥ 24	15 < > 25	max. 300 cm

FT

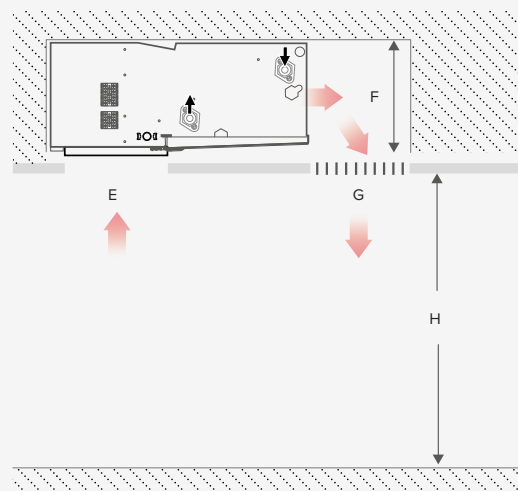

	E	F	G	H*
L (inches)	10"	≥ 10½"	6" < > 10"	max. 10 ft
L (cm)	25	≥ 26	15 < > 25	max. 300 cm

*For heating application vertical air throw depends on water temperatures, fan speed and room geometry.

2-pipe performance

JAGA SELECTION MODEL

Speed level	Control voltage	Heating power*		Cooling power 50% RH*		Electrical power	Air flow
		170 / 150 / 68°F	95 / 85 / 68°F	45 / 55 / 80°F			
%	V	BTU/h	BTU/h	BTU/h	BTU/h	W	CFM
T2 / 55							
20	2	8213	1879	2330	3141	3.7	84
40	4	16149	3695	4731	6047	12.5	184
60	6	22431	5133	6593	8211	31.3	273
80	8	28745	6577	7915	9876	58.2	346
100	10	34866	7978	8773	10752	86.5	399
T3 / 75							
20	2	8067	1958	2635	3664	3.1	81
40	4	18112	4396	5627	7754	9.1	188
60	6	26443	6418	8160	10951	22.6	296
80	8	32322	7845	10004	13677	43.6	394
100	10	35497	8616	11040	14469	65.3	462
T4 / 95							
20	2	9951	2246	3144	4376	3.2	109
40	4	26810	6050	8229	11037	11	270
60	6	38233	8629	11619	15223	27.1	407
80	8	45594	10290	13753	18267	51.6	521
100	10	48750	11002	14644	18791	70.4	583

Sound data upon request.

* Values according EN 1397 and all capacity data at 0" ESP

BRIZA 22



TECHNICAL DATA

Speed level	Control voltage	Heating power*		Cooling power 50% RH*		Electrical power	Air flow
		170 / 150 / 68°F	95 / 85 / 68°F	45 / 55 / 80°F			
				Sensible	Total		
%	V	BTU/h	BTU/h	BTU/h	BTU/h	W	CFM
T6 / 125							
20	2	15749	3751	4265	5916	6.5	163
40	4	33002	7861	9013	12276	20.7	373
60	6	47259	11257	13321	17382	51	576
80	8	57603	13721	16798	22409	97.4	750
100	10	64005	15246	19192	22752	147	876
T8 / 155							
20	2	15858	3849	4712	6531	6.4	195
40	4	35748	8677	10803	14602	20	445
60	6	54146	13142	16481	21696	49.8	690
80	8	69073	16766	21123	28282	95.1	900
100	10	78215	18984	23985	30621	138.1	1034
T10 / 190							
20	2	22544	5461	7023	9780	9.8	237
40	4	49587	12012	15415	21272	30.9	540
60	6	74571	18064	23072	31482	75.2	843
80	8	94689	22937	29153	39946	140.4	1107
100	10	107105	25944	32860	44104	204	1281

Sound data upon request.

* Values according EN 1397 and all capacity data at 0" ESP

4-pipe performance

Speed level	Control voltage	Heating power* 		Cooling power 50% RH* 		Electrical power	Air flow
		170 / 150 / 68°F	95 / 85 / 68°F	45 / 55 / 80°F			
%	V	BTU/h	BTU/h	BTU/h	BTU/h	W	CFM
T2 / 55							
20	2	4920	958	2330	3142	3.7	84
40	4	7380	1438	4731	6047	12.5	184
60	6	9135	1779	6593	8211	31.3	273
80	8	10258	1998	7915	9867	58.2	346
100	10	10907	2125	8773	10752	86.5	399
T3 / 75							
20	2	4731	923	2635	3664	3.1	81
40	4	8977	1751	5627	7754	9.1	188
60	6	11832	2307	8160	10951	22.6	296
80	8	13418	2617	10004	13677	43.6	394
100	10	14104	2751	11040	14469	65.3	462
T4 / 95							
20	2	6543	1258	3144	4376	3.2	109
40	4	12817	2464	8229	11037	11	270
60	6	16062	3088	11619	15223	27.1	407
80	8	17682	3400	13753	18267	51.6	521
100	10	18269	3513	14644	18791	70.4	583

Sound data upon request.

* Values according EN 1397 and all capacity data at 0" ESP

Speed level	Control voltage	Heating power*		Cooling power 50% RH*		Electrical power	Air flow
		170 / 150 / 68°F	95 / 85 / 68°F	45 / 55 / 80°F			
				Sensible	Total		
%	V	BTU/h	BTU/h	BTU/h	BTU/h	W	CFM
T6 / 125							
20	2	12242	2484	4265	5916	6.5	163
40	4	19039	3863	9013	12276	20.7	373
60	6	24139	4898	13321	17382	51	576
80	8	27366	5552	16798	22409	97.4	750
100	10	29041	5892	19192	22752	147	876
T8 / 155							
20	2	11338	2350	4712	6531	6.4	195
40	4	21289	4412	10803	14602	20	445
60	6	29288	6070	16481	21696	49.8	690
80	8	34778	7208	21123	28282	95.1	900
100	10	37630	7799	23985	30621	138.1	1034
T10 / 190							
20	2	17391	3587	7023	9780	9.8	237
40	4	30616	6315	15415	21272	30.9	540
60	6	41131	8484	23072	31482	75.2	843
80	8	48099	9921	29153	39946	140.4	1107
100	10	51576	10638	32860	44104	204	1281

Sound data upon request.

* Values according EN 1397 and all capacity data at 0" ESP

Air filtration

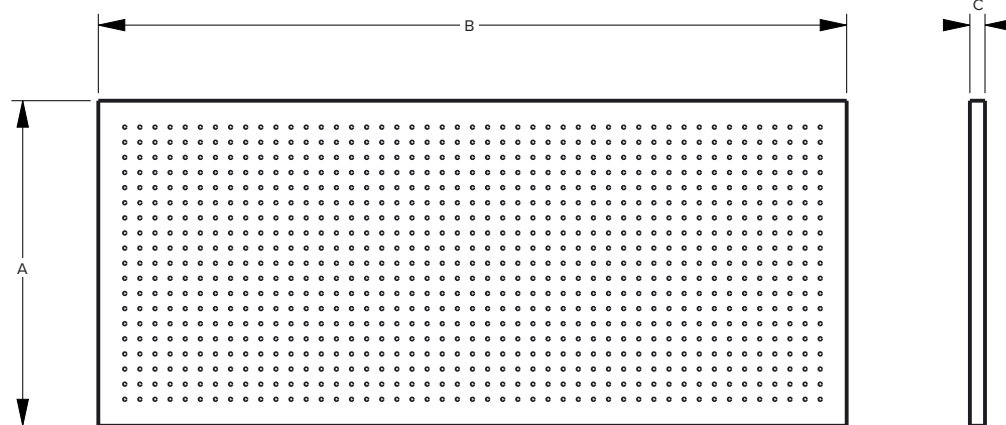

All types available in MERV 4, 8 or 13 media

BRIZA 22

AIR FILTRATION

DIMENSIONS

MODEL	T2 / 55	T3 / 75	T4 / 95	T6 / 125	T8 / 155	T10 / 190
Code	8.721.401	8.721.402	8.721.403	8.721.404	8.721.405	8.721.406
L (inch)	19 1/2"	27 3/8"	35 1/4"	47 1/16"	58 7/8"	2x 35 1/4"
L (mm)	495	695	895	1.195	1495	2x 895

	A*	B*	C**
L (inches)	8 7/16"	L	1"
L (mm)	215	L	25

* ±1/16" or 1,5 mm

** 1", 2" or 4" deep filters available



Casing

Wall mounted configuration

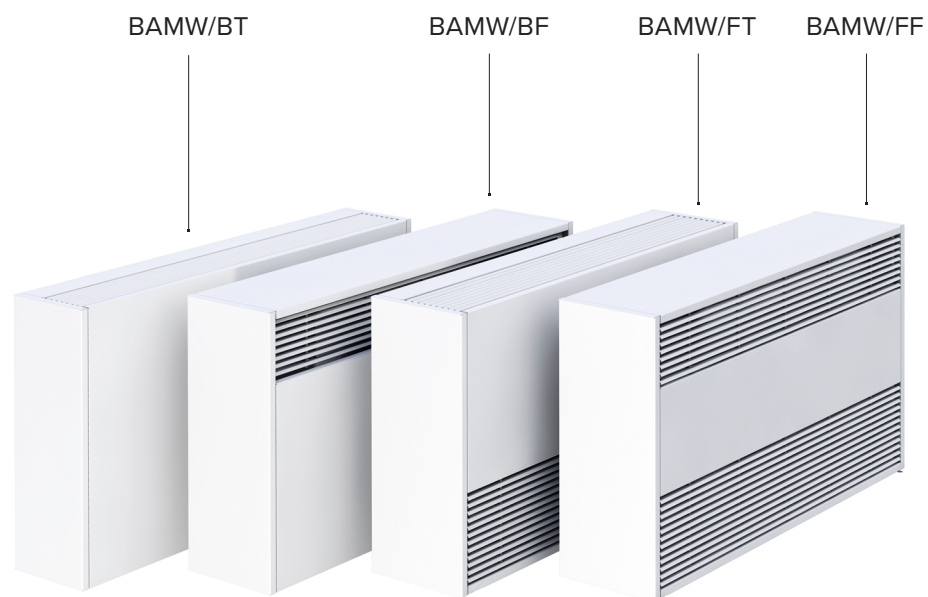

BRIZA 22

WALL MOUNTED

Wall mounted configuration



TYPE: BAMW/BT

Wall mounted standard

- Supply air at the top
- Return air at the bottom

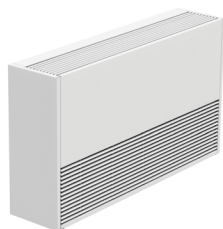

TYPE: BAMW/FT

Wall mounted (optional)

- Supply air at the top
- Return air at the front
- Increased width for filter 3/4"

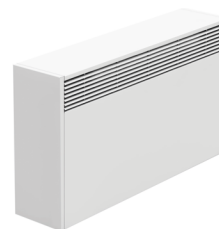

TYPE: BAMW/BF

Wall mounted (optional)

- Supply air at the front
- Return air at the bottom
- Increased width for filter 3/4"

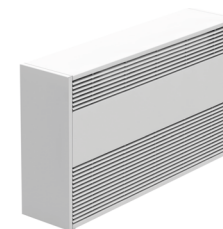

TYPE: BAMW/FF

Wall mounted (optional)

- Supply air at the front
- Return air at the front
- Increased width for filter 3/4"

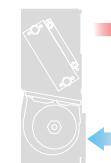

Supply/return air configurations and options

TYPE: BABW/BT

standard return air +
standard supply air



TYPE: BABW/FT

CONFIGURATION front return
air + standard supply air

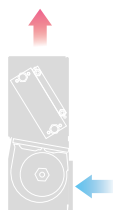

TYPE: BABW/BF

standard return air +
CONFIGURATION front
supply air



TYPE: BABW/FF

CONFIGURATION front return
air + CONFIGURATION front
supply air



OPTION air mixing box. See page 77.

0..10 V Modulating motor



OPEN

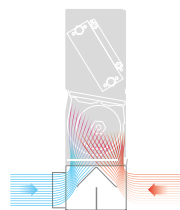

MIX

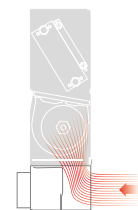

CLOSE



Dimensions

MODEL	T2 / 55	T3 / 75	T4 / 95	T6 / 125	T8 / 155	T10 / 190
Code	BABW	BABW	BABW	BABW	BABW	BABW
L (inches)	37 1/2"	43 1/4"	51 1/8"	63"	74 7/8"	88 9/16"
L (cm)	95	110	130	160	190	225



DIMENSIONS

BT

BF / FF / FT

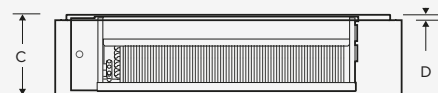

Primary coil

Secondary coil

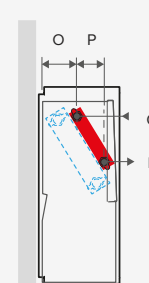
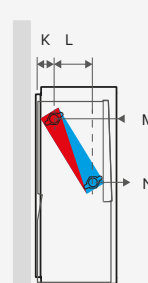
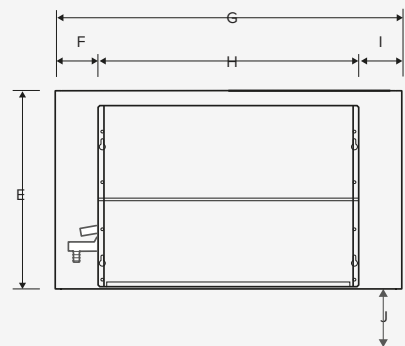
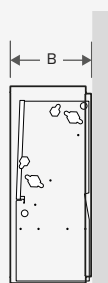
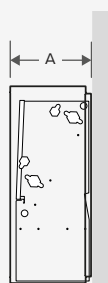

	A	B	C	D	E	F	G	H	I	J	K	L	M	N	O	P	Q	R
L (inches)	9 1/8"	10 5/8"	9 1/8"*/10 5/8"	5/8"	24 5/8"	6 7/8"	L	L-13 3/4"	6 7/8"	4"	2"	4 1/4"	3/4" NPT	3/4" NPT	4 1/8"	3 1/2"	1/2" NPT	1/2" NPT
L (cm)	23	27	23*/27	1.5	62.5	17.5	L	L-35	17.5	10	5	11	3/4" NPT	3/4" NPT	10.5	9	1/2" NPT	1/2" NPT

*BF only

Ceiling mounted configuration

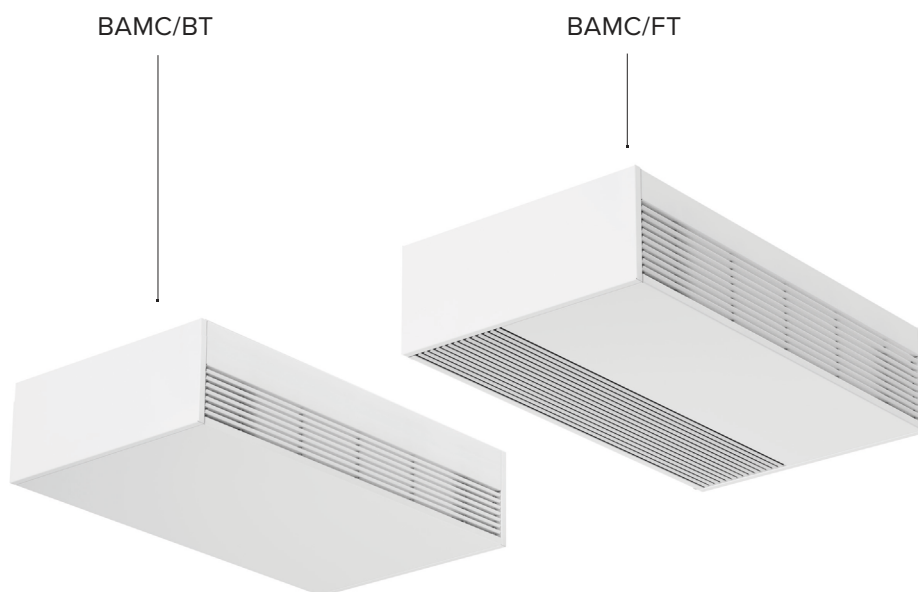

BRIZA 22

CEILING MOUNTED

Ceiling mounted configuration

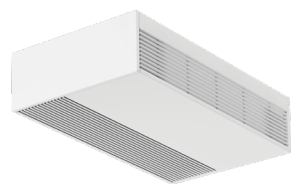

TYPE: BAMC/BT

Ceiling mounted standard

- Return air at the bottom
- Supply air at the top

TYPE: BAMC/FT

Ceiling mounted (optional)

- Return air at the front
- Supply air at the top
- Increased width for filter



Supply/return air configurations

TYPE: BAMC/BT

standard return air + standard supply air



TYPE: BAMC/FT

CONFIGURATION front return air + standard supply air



Dimensions

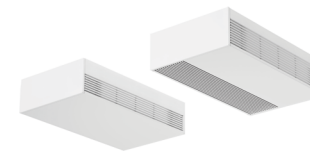

MODEL	T2 / 55	T3 / 75	T4 / 95	T6 / 125	T8 / 155	T10 / 190
Code	BAMC	BAMC	BAMC	BAMC	BAMC	BAMC
L (inches)	37 1/2"	43 1/4"	51 1/8"	63"	74 7/8"	88 9/16"
L (cm)	95	110	130	160	190	225



DIMENSIONS

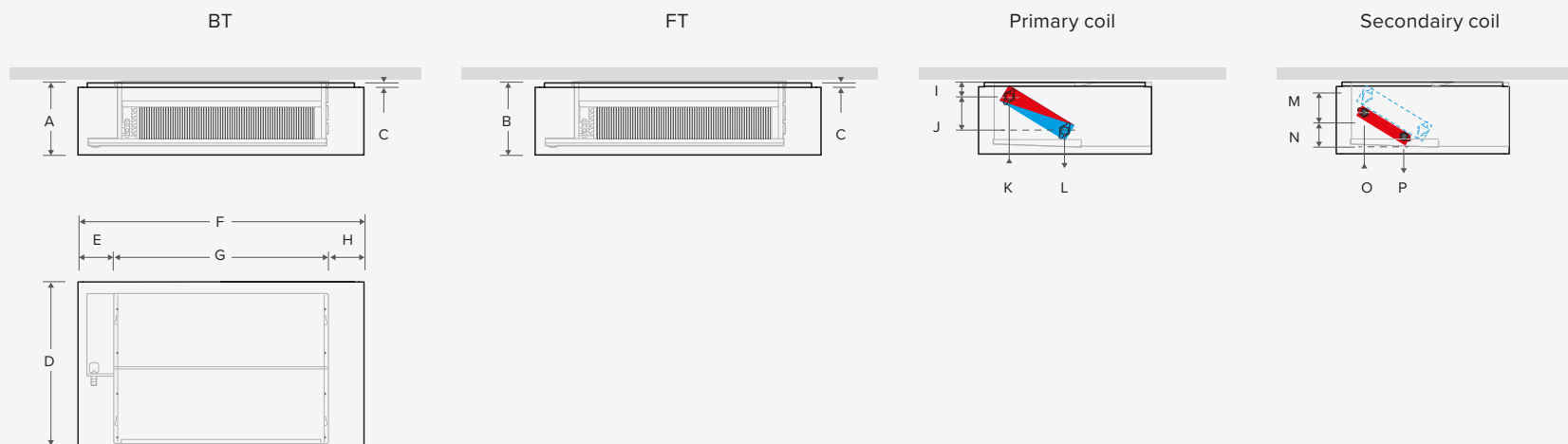

	A	B	C	D	E	F	G	H	I	J	K	L	M	N	O	P
L (inches)	9 1/16"	10 5/8"	5/8"	24 5/8"	6 7/8"	L	L-13 3/4"	6 7/8"	2"	4 1/4"	3/4" NPT	3/4" NPT	4 1/8"	3 1/2"	1/2" NPT	1/2" NPT
L (cm)	23	27	1.5	62.5	17.5	L	L-35	17.5	5	11	3/4" NPT	3/4" NPT	10.5	9	1/2" NPT	1/2" NPT

Freestanding configuration

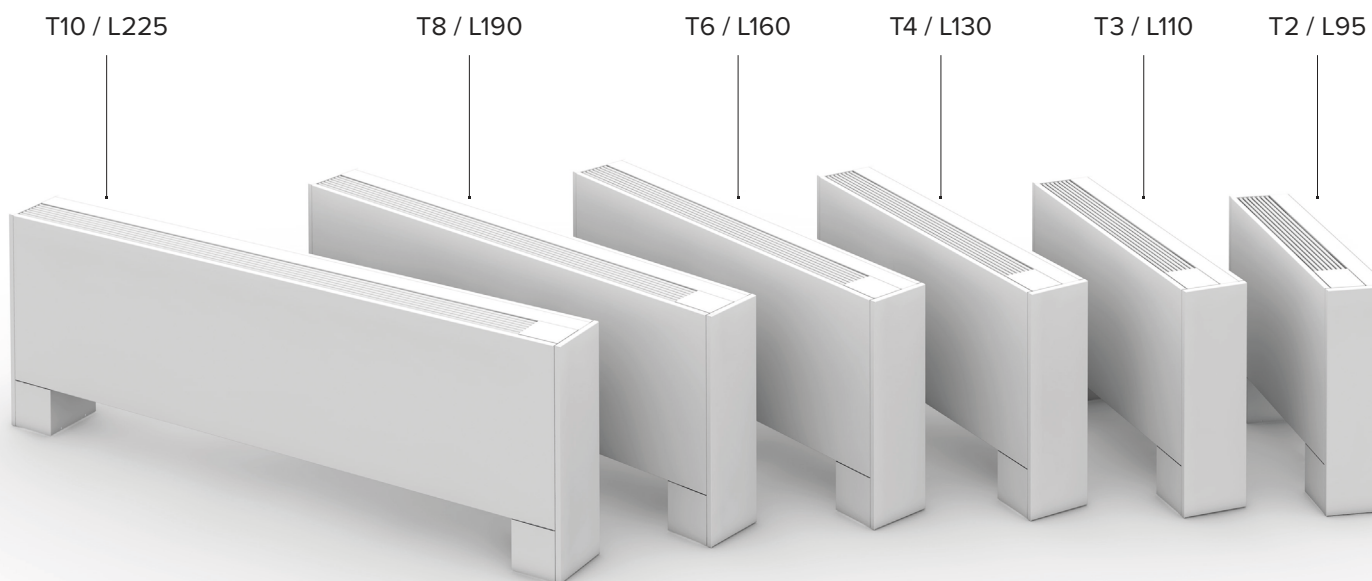

BRIZA 22

FREESTANDING

Freestanding configuration

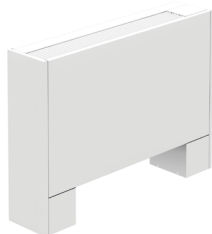

TYPE: BAMF/BT

- supply air at the bottom
- exhaust air at the top



Dimensions



MODEL	T2 / 55	T3 / 75	T4 / 95	T6 / 125	T8 / 155	T10 / 190
Code	BAMF	BAMF	BAMF	BAMF	BAMF	BAMF
L (inches)	37 1/2"	43 1/4"	51 1/8"	63"	74 7/8"	88 9/16"
L (cm)	95	110	130	160	190	225

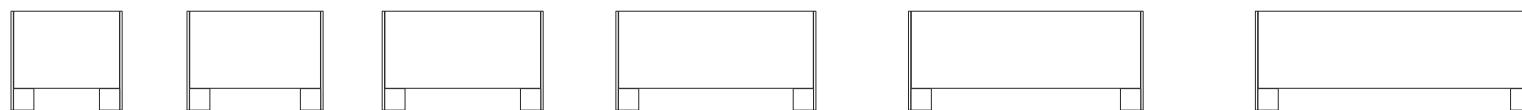

DIMENSIONS

	A	B	C	D	E	F	G	H	I	J	K	L	M	N	O
L (inches)	4 15/16"	9 1/16"	31 1/2"	6 7/8"	L	L-13 3/4"	6 7/8"	1 15/16"	4 5/16"	3/4" NPT	3/4" NPT	4 1/8"	3 9/19"	1/2" NPT	1/2" NPT
L (cm)	12.5	23	80	17.5	L	L-35	17.5	5	11	3/4" NPT	3/4" NPT	10.5	9	1/2" NPT	1/2" NPT

BRIZA 22

FREESTANDING

2-pipe performance

JAGA SELECTION MODEL

Speed level	Control voltage	Heating power*		Cooling power 50% RH*		Electrical power	Air flow
		170 / 150 / 68°F	95 / 85 / 68°F	45 / 55 / 80°F			
%	V	BTU/h	BTU/h	BTU/h	BTU/h	W	CFM
T2 / 55							
20	2	7142	1634	2045	2825	3.5	73
40	4	14437	3304	4181	5633	11.6	160
60	6	19824	4536	5875	7746	28.8	237
80	8	24580	5624	7107	9378	53.7	300
100	10	28808	6592	7926	10312	81.2	346
T3 / 75							
20	2	6966	1691	2310	3226	3.0	70
40	4	15956	3873	4980	6901	8.6	163
60	6	23675	5746	7311	10082	21.3	258
80	8	29402	7137	9080	12497	41.2	343
100	10	32695	7936	10124	13926	61.5	402
T4 / 95							
20	2	8265	1865	2632	3678	3.1	95
40	4	23419	5285	7212	9944	10.2	234
60	6	34125	7701	10407	14129	25.4	354
80	8	41411	9346	12547	17205	48.2	453
100	10	44720	10093	13503	18234	68.7	506



Sound data upon request.

* Values according EN 1397

Speed level	Control voltage	Heating power*		Cooling power 50% RH*		Electrical power	Air flow
		170 / 150 / 68°F	95 / 85 / 68°F	45 / 55 / 80°F			
%	V	BTU/h	BTU/h	BTU/h	BTU/h	W	CFM
T6 / 125							
20	2	13853	3300	3766	5248	6.3	141
40	4	29208	6957	7933	10970	19.7	324
60	6	42225	10058	11748	16111	47.9	500
80	8	51968	12379	14857	20422	91.2	652
100	10	58204	13864	17014	22607	136.7	761
T8 / 155							
20	2	13767	3341	4075	5674	6.2	169
40	4	31203	7573	9407	12990	19.0	387
60	6	47458	11519	14412	19704	46.6	599
80	8	60754	14746	18531	25443	89.0	781
100	10	68951	16736	21085	28437	130.2	898
T10 / 190							
20	2	19655	4761	6121	8559	9.7	206
40	4	43441	10523	13516	18752	29.2	469
60	6	65667	15907	20355	28113	70.9	732
80	8	83785	20296	25868	35670	132.2	962
100	10	95089	23034	29273	40327	190.6	1112



Sound data upon request.
* Values according EN 1397

4-pipe performance

Speed level	Control voltage	Heating power* 		Cooling power 50% RH* 		Electrical power	Air flow
		170 / 150 / 68°F	95 / 85 / 68°F	45 / 55 / 80°F			
%	V	BTU/h	BTU/h	BTU/h	BTU/h	W	CFM
T2 / 55							
20	2	4617	899	2045	2825	3.5	73
40	4	6833	1331	4181	5633	11.6	160
60	6	8478	1652	5875	7746	28.8	237
80	8	9586	1867	7107	9378	53.7	300
100	10	10266	2000	7926	10312	81.2	346
T3 / 75							
20	2	4218	823	2310	3226	3.0	70
40	4	8135	1586	4980	6901	8.6	163
60	6	10957	2137	7311	10082	21.3	258
80	8	12679	2473	9080	12497	41.2	343
100	10	13505	2634	10124	13926	61.5	402
T4 / 95							
20	2	5826	1120	2632	3678	3.1	95
40	4	11691	2248	7212	9944	10.2	234
60	6	14995	2883	10407	14129	25.4	354
80	8	16807	3231	12547	17205	48.2	453
100	10	17509	3366	13503	18234	68.7	506

Sound data upon request.

* Values according EN 1397

Speed level	Control voltage	Heating power* 		Cooling power 50% RH* 		Electrical power	Air flow
		170 / 150 / 68°F	95 / 85 / 68°F	45 / 55 / 80°F			
				Sensible	Total		
%	V	BTU/h	BTU/h	BTU/h	BTU/h	W	CFM
T6 / 125							
20	2	11465	2326	3766	5248	6.3	141
40	4	17593	3569	7933	10970	19.7	324
60	6	22408	4546	11748	16111	47.9	500
80	8	25672	5209	14857	20422	91.2	652
100	10	27536	5587	17014	22607	136.7	761
T8 / 155							
20	2	10222	2118	4075	5674	6.2	169
40	4	19126	3964	9407	12990	19.0	387
60	6	26527	5498	14412	19704	46.6	599
80	8	31838	6598	18531	25443	89.0	781
100	10	34737	7199	21085	28437	130.2	898
T10 / 190							
20	2	15882	3276	6121	8559	9.7	206
40	4	27763	5726	13516	18752	29.2	469
60	6	37597	7755	20355	28113	70.9	732
80	8	44509	9180	25868	35670	132.2	962
100	10	48222	9946	29273	40327	190.6	1112

Sound data upon request.
* Values according EN 1397

Air filtration

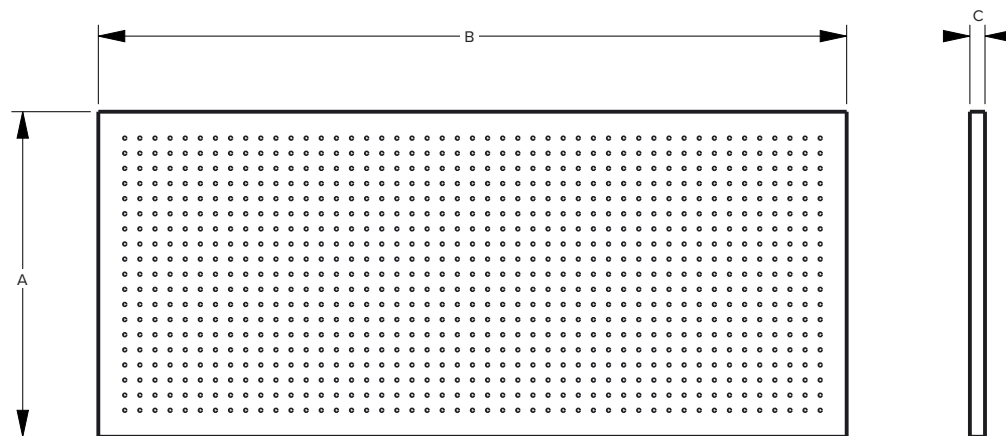

All types available in MERV 4, 8 or 13 media

BRIZA 22

AIR FILTRATION

DIMENSIONS

MODEL	T2 / 55	T3 / 75	T4 / 95	T6 / 125	T8 / 155	T10 / 190
Code	8.721.401	8.721.402	8.721.403	8.721.404	8.721.405	8.721.406
L (inch)	19 1/2"	27 3/8"	35 1/4"	47 1/16"	58 7/8"	2x 35 1/4"
L (mm)	495	695	895	1.195	1495	2x 895

	A*	B*	C**
L (inches)	8 7/16"	L	1"
L (mm)	215	L	25

* ±1/16" or 1,5 mm

** 1", 2" or 4" deep filters available



Built-in HP

Built-in HP configuration

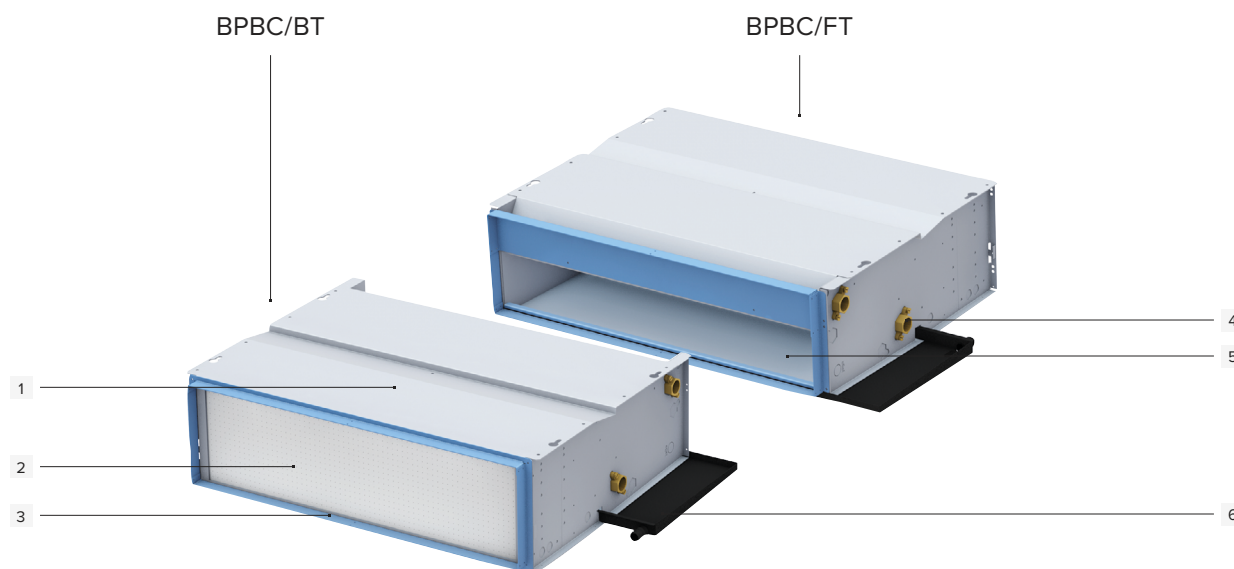

- 1 Casing in reinforced galvanized steel
- 2 Replaceable filter
- 3 Electrical connection, standard right*
- 4 Hydraulic connection: $\frac{3}{4}$ " NPT standard left
- 5 Aluminum-copper coil with hydrophilic coating
- 6 Condensate drain, connection $\frac{3}{4}$ "
- 7 Centrifugal fan(s) with double inlet
- 8 Flanges to connect ductwork

*Same side electrical and hydronic connections available for ceiling mounted units upon request

Built-in HP configuration

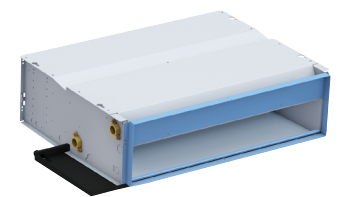
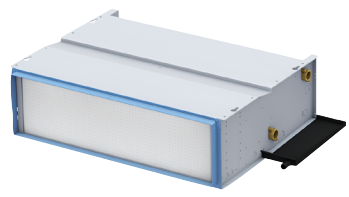

TYPE: BPBC/BT

TYPE: BPBC/FT

- Flange on the return air side

- Flange on the supply air side



Supply/return air configurations and options

TYPE: BPBC/BT

standard return air +
standard supply air



TYPE: BPBC/FT

CONFIGURATION front return
air + standard supply air



OPTION 90° corner piece. See page 81.

standard return air +
OPTION 90° supply air



OPTION front return air +
OPTION 90° supply air

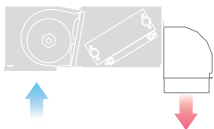

OPTION plenum connections
See page 86.

OPTION return air +
OPTION supply air



OPTION 90° corner piece
See page 81.

OPTION 90° return air +
OPTION 90° supply air



Dimensions

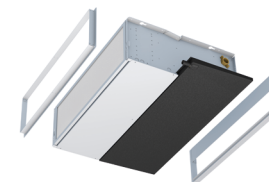

MODEL	T3 / 75	T4 / 95	T6 / 125	T8 / 155	T10 / 190
Code	BPBC	BPBC	BPBC	BPBC	BPBC
L (inches)	43 1/4"	51 1/8"	63"	74 7/8"	88 9/16"
L (cm)	75	95	125	155	190



DIMENSIONS

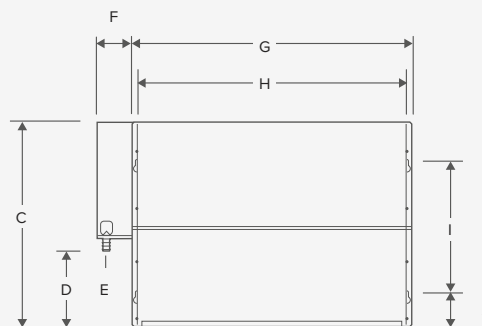
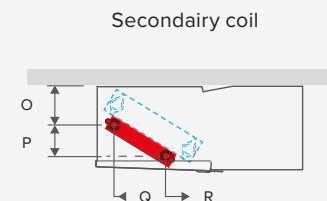
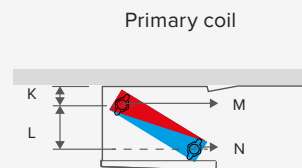

	A	B	C	D	E	F	G	H	I	J	K	L	M	N	O	P	Q	R
L (inches)	8 3/4"	9 1/8"	21 1/2"	7 7/8"	7/8"	3 5/8"	L	L-1"	13 3/4"	3 1/2"	2"	4 1/8"	3/4" NPT	3/4" NPT	4 1/8"	3 1/2"	1/2" NPT	1/2" NPT
L (cm)	22.2	23.2	54.5	20	2	9.35	L	L-2.5	35	9	5	11	3/4" NPT	3/4" NPT	10.5	9	1/2" NPT	1/2" NPT

2-pipe performance

JAGA SELECTION MODEL

Speed level	Control voltage	Heating power*		Cooling power 50% RH*		Electrical power	Air flow
		170 /150 / 68°F	95 / 85 / 68°F	45 / 55 / 80°F			
%	V	BTU/h	BTU/h	Sensible BTU/h	Total BTU/h	W	CFM
T3 / 75							
25	5	37727	8313	11779	13412	63.5	468
50	6	40897	9011	12890	14655	95.2	558
75	7	42555	9377	13565	15423	134.4	639
100	8	43088	9494	13937	15845	177.9	721
T4 / 95							
25	5	49903	11557	15921	18139	76.1	626
50	6	53612	12416	16945	19265	114	744
75	7	54785	12687	17214	19571	147.2	808
100	8	55339	12816	17283	19649	171.3	867
T6 / 125							
25	5	59275	13411	17752	20216	86	750
50	6	66201	14978	20417	23212	126.7	883
75	7	68741	15553	21475	24415	153.6	937
100	8	70882	16037	22412	25480	177.8	987

* Values according EN 1397 and all capacity data at 0° ESP

Speed level	Control voltage	Heating power* 		Cooling power 50% RH* 		Electrical power	Air flowrate
		170 /150 / 68°F	95 / 85 / 68°F	45 / 55 / 80°F			
%	V	BTU/h	BTU/h	BTU/h	BTU/h	W	CFM
T8 / 155							
25	5	79161	18365	25075	28596	137.9	1018
50	6	92794	21528	29512	33553	205.5	1221
75	7	101599	23570	32399	36835	278.4	1358
100	8	109579	25422	35032	39829	350.9	1487
T10 / 190							
25	5	108696	25808	34925	45922	156.1	1286
50	6	124137	29474	39689	52186	224.8	1514
75	7	132577	31478	42257	55563	290.4	1646
100	8	1402627	33390	44680	58749	347.6	1779



* Values according EN 1397 and all capacity data at 0° ESP

4-pipe performance

Speed level	Control voltage	Heating power*		Cooling power 50% RH*		Electrical power	Air flowrate
		170 /150 / 68°F	95 / 85 / 68°F	45 / 55 / 80°F			
%	V	BTU/h	BTU/h	Sensible BTU/h	Total BTU/h	W	CFM
T3 / 75							
25	5	14460	2713	11779	13412	63.5	468
50	6	14998	2814	12890	14655	95.2	558
75	7	15272	2866	13565	15423	134.4	639
100	8	15499	2908	13937	15845	177.9	721
T4 / 95							
25	5	18334	3616	15921	18139	76.1	626
50	6	19027	3752	16945	19265	114	744
75	7	19374	3821	17214	19571	147.2	808
100	8	19738	3893	17283	19649	171.3	867
T6 / 125							
25	5	28172	5428	17752	20216	86	750
50	6	29976	5775	20417	23212	126.7	883
75	7	30532	5883	21475	24415	453.6	937
100	8	30942	5962	22412	25480	177.8	987

* Values according EN 1397



Speed level	Control voltage	Heating power* 		Cooling power 50% RH* 		Electrical power	Air flowrate
		170 /150 / 68°F	95 / 85 / 68°F	45 / 55 / 80°F			
				Sensible	Total		
%	V	BTU/h	BTU/h	BTU/h	BTU/h	W	CFM
T8 / 155							
25	5	37333	7733	25075	28969	137.9	704.4
50	6	40764	8443	29512	33553	205.5	844.7
75	7	42419	8786	32399	36835	278.4	939.6
100	8	43488	9008	35032	39829	350.9	1028.8
T10 / 190							
25	5	52256	10565	39425	45922	156.1	1286
50	6	55480	11217	39689	52186	224.8	1514
75	7	56646	11453	42257	55563	290.4	1646
100	8	57293	11584	44680	58749	347.6	1779

* Values according EN 1397 and all capacity data at 0° ESP

Air filtration

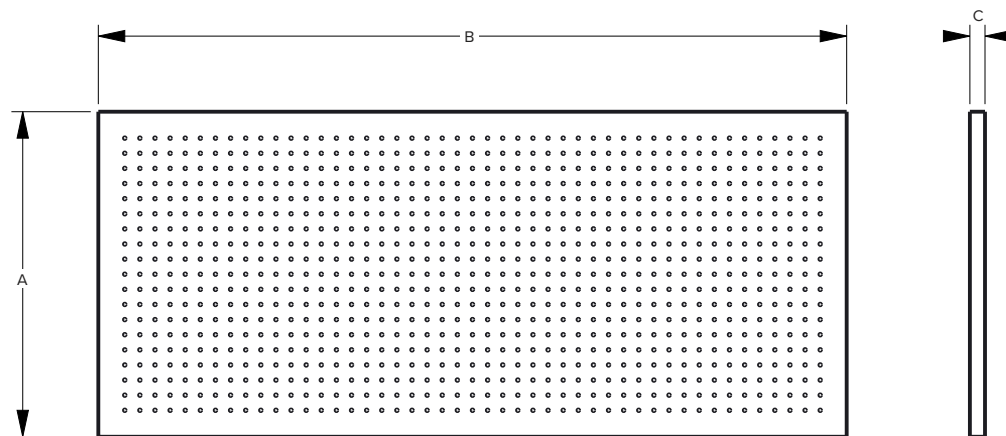

All types available in MERV 4, 8 or 13 media

BRIZA 22

AIR FILTRATION

DIMENSIONS

MODEL	T2 / 55	T3 / 75	T4 / 95	T6 / 125	T8 / 155	T10 / 190
Code	8.721.401	8.721.402	8.721.403	8.721.404	8.721.405	8.721.406
L (inch)	19 1/2"	27 3/8"	35 1/4"	47 1/16"	58 7/8"	2x 35 1/4"
L (mm)	495	695	895	1.195	1495	2x 895

	A*	B*	C**
L (inches)	8 7/16"	L	1"
L (mm)	215	L	25

* ±1/16" or 1,5 mm

** 1", 2" or 4" deep filters available



Options

Electric heater

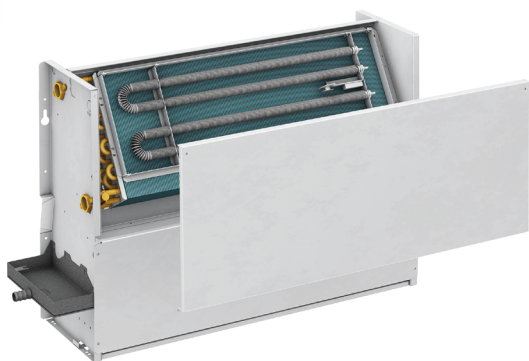

Electrical resistance, made of stainless steel

- With safety device for overheating
- With relay

System configuration Briza 22 with electrical resistance:

- Briza 22 standard coil for cooling
- Optional auxiliary electrical resistance for heating

MODEL	T2 / 55	T3 / 75	T4 / 95	T6 / 125	T8 / 155	T10 / 190
Code	8721.6021	8721.6022	8721.6023	8721.6024	8721.6025	8721.6026
Voltage	120V/60Hz	120V/60Hz	120V/60Hz	120V/60Hz	120V/60Hz	120V/60Hz
KW	1	1	1.5	2	2	2.5
A	8.6 (9.3 with fan)	8.6 (9.1 with fan)	13 (13.6 with fan)	17 (18.2 with fan)	17 (18.2 with fan)	21 (22.7 with fan)
mm ²	1.5	1.5	1.5	2.5	2.5	2.5

DIMENSIONS

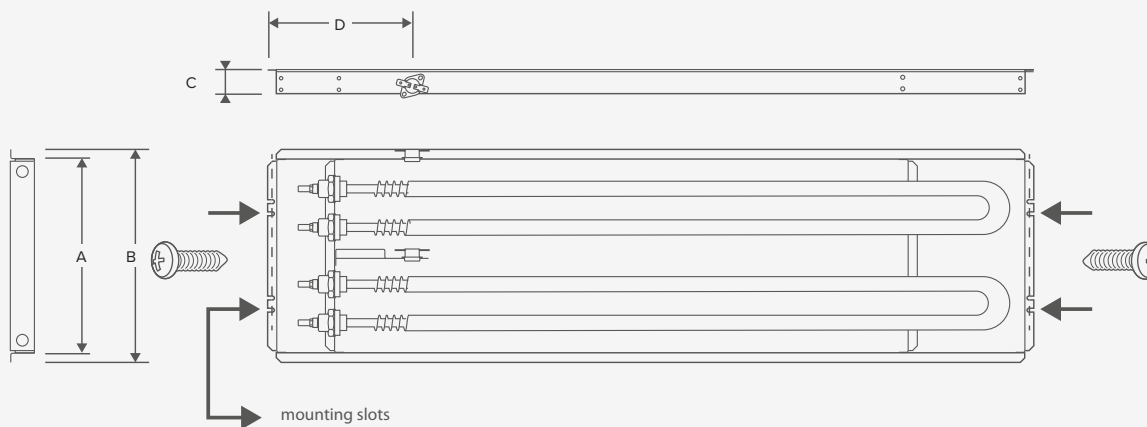

	A	B	C	D
L (inches)	7 7/8"	8 1/16"	1"	5 7/8"
L (cm)	20	22	2.5	15

Mounting

Electric resistance:

- Screw the element against the coil. The mounting slots in the heating element correspond to the punched screw holes in the coil.

Relays:

- Screw the relay (with two screws) to the Briza console

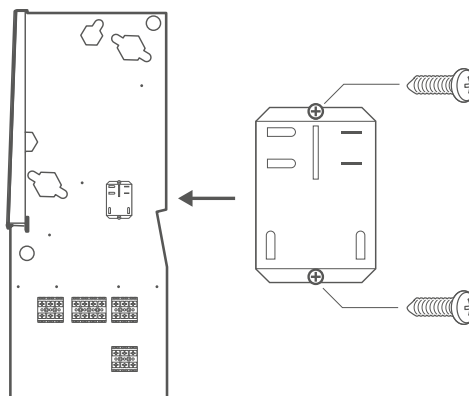

⚠ ATTENTION!!

- The electrical resistance must not be switched on without the fan running
- The air outlet grille (on the top of the appliance) must never be covered or closed. Covering the grill can damage the appliance and disrupt the operation of the appliance.
- Ensure free air supply and exhaust

Wiring

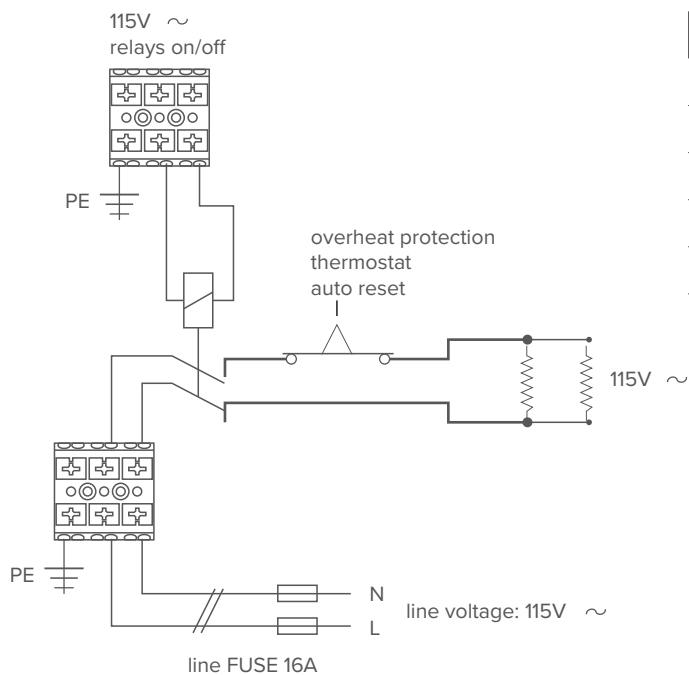

MODEL	T2 / 55	T3 / 75	T4 / 95	T6 / 125	T8 / 155	T10 / 190
Voltage	115V/60Hz	115V/60Hz	115V/60Hz	115V/60Hz	115V/60Hz	115V/60Hz
KW	1	1	1.5	2	2	2.5
A	8.6 (9.3 w/fan)	8.6 (9.1 w/fan)	13 (13.6 w/fan)	17 (18.2 w/fan)	17 (18.2 w/fan)	21 (22.7 w/fan)
AWG	14	14	14	12	12	12
mm ²	2.5	2.5	2.5	2.5	2.5	2.5

Air mixing box

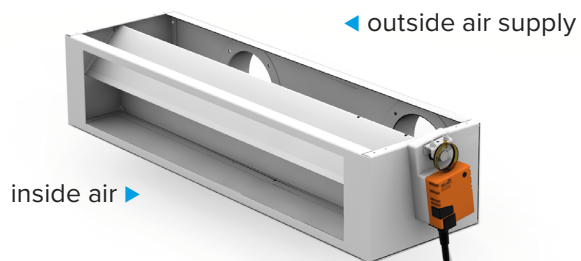

- 115V motorized air mixer, with modulating adjustable damper (damper position determined by modulating 0...10V signal).
- Connection \varnothing 5"
- Dark grey painted steel plate - RAL 7024

DIMENSIONS

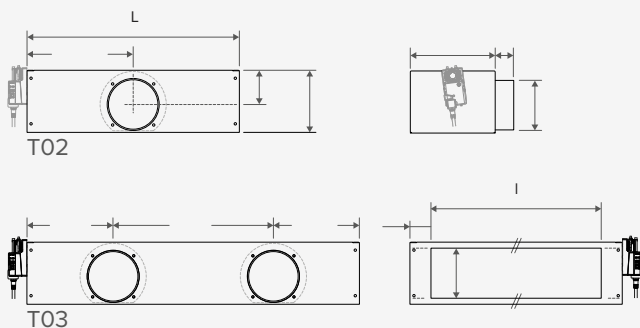

MODEL	T2 / 55	T3 / 75	T4 / 95	T6 / 125	T8 / 155	T10 / 190
Code	8763.0301	8763.0302	8763.0303	8763.0304	8763.0305	8763.0306
L (inches)	20 $\frac{7}{8}$ "	32 $\frac{1}{16}$ "	36 $\frac{5}{8}$ "	48 $\frac{7}{16}$ "	60 $\frac{1}{4}$ "	75 $\frac{63}{64}$ "
l (inches)	16 $\frac{3}{4}$ "	28 $\frac{9}{16}$ "	32 $\frac{1}{2}$ "	44 $\frac{5}{16}$ "	56 $\frac{1}{8}$ "	71 $\frac{7}{8}$ "
L (cm)	53	83	93	123	153	193
l (cm)	42.5	72.5	82.5	112.5	142.5	182.5

DIMENSIONS

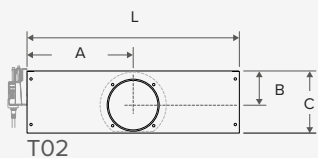

	A	B	C	D	E	F
L (inches)	10 7/16"	3 3/8"	6 1/8"	8 1/4"	1 3/4"	4 15/16"
L (cm)	26.5	8.5	15.5	21	4.5	12.5

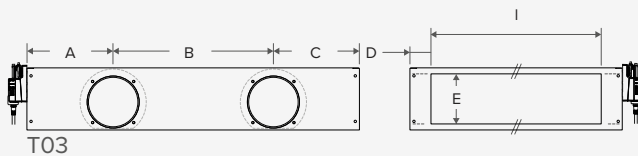

	A	B	C	D	E
L (inches)	7 5/16"	14 3/16"	7 5/16"	2 1/16"	4 15/16"
L (cm)	18.5	36	18.5	5.25	12.5

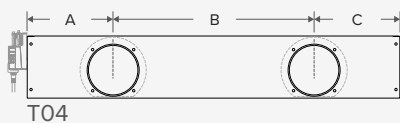

	A	B	C
L (inches)	8 7/16"	19 1/16"	8 7/16"
L (cm)	21.5	50	21.5

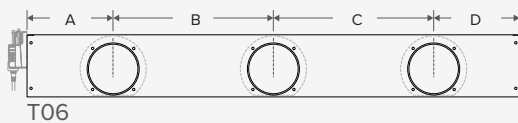

	A	B	C	D
L (inches)	8 7/16"	15 3/4"	15 3/4"	8 7/16"
L (cm)	21.5	40	40	21.5

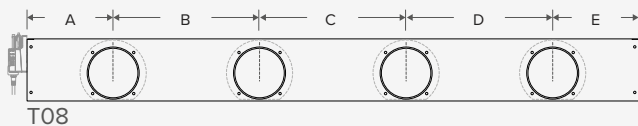

	A	B	C	D	E
L (inches)	8 7/16"	14 9/16"	14 9/16"	14 9/16"	8 7/16"
L (cm)	21.75	37	37	37	21.75

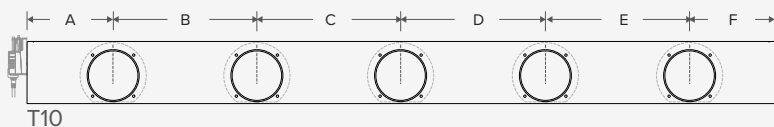

	A	B	C	D	E	F
L (inches)	8 1/16"	14 3/16"	14 3/16"	14 3/16"	14 3/16"	8 1/16"
L (cm)	22	36	36	36	36	22

Servomotor 115 V, modulating

Description: modulating damper actuator for adjusting dampers in technical building installations

- Torque motor 5 nm
- Nominal voltage ac 115 V
- Control modulating 2...10 V
- Position feedback 2...10 V
- Adjustable rotation angle with mechanical stops.
- High functional reliability, the actuator is protected against overload, does not require electrical limit switches and stops automatically when the mechanical stops are reached.

Wiring diagram

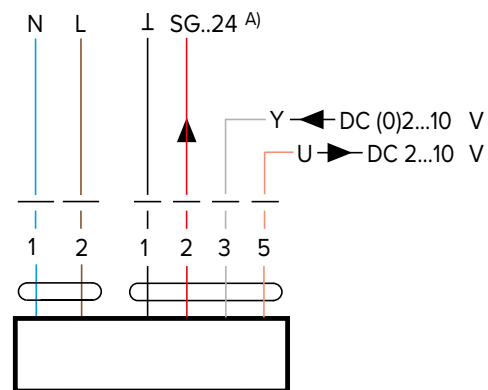

Cable colours

- 1 = blue
- 2 = brown
- 1 = black
- 2 = red
- 3 = white
- 5 = orange

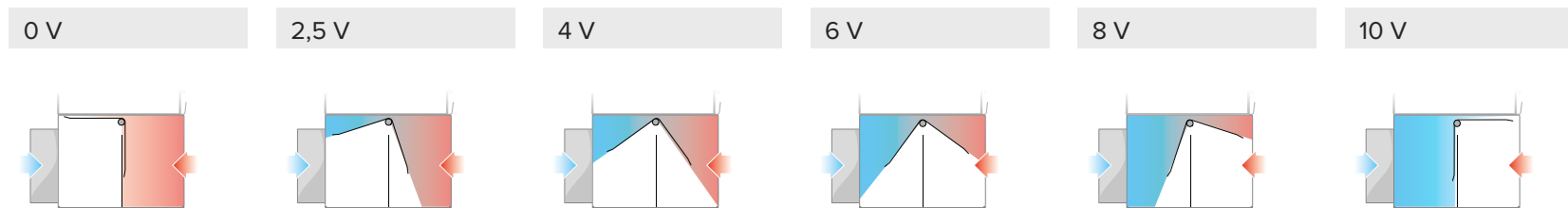

Condensate overflow switch

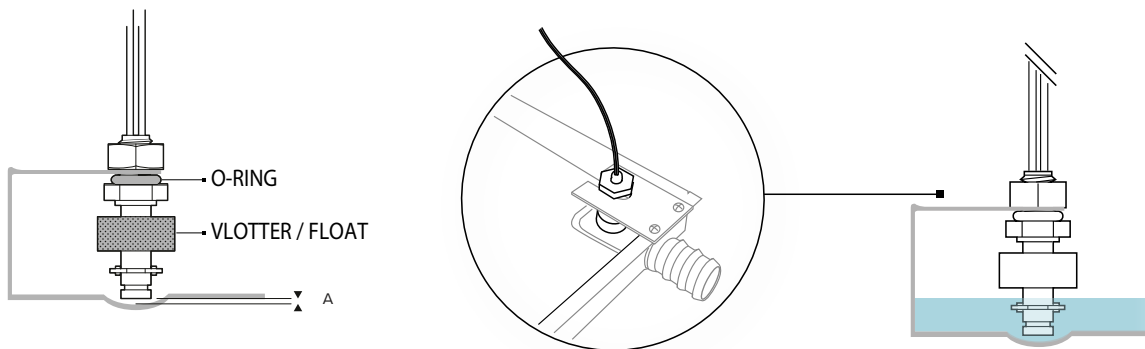

- Normally closed (NC)
- Max contact rating 10W
- Max contact voltage 100VDC
- Max switching current 0.5A

	A
L (inches)	1/16"
L (cm)	1

Code	5127.00010003
------	---------------

Mounting bracket for condensate overflow switch (for ceiling version only)

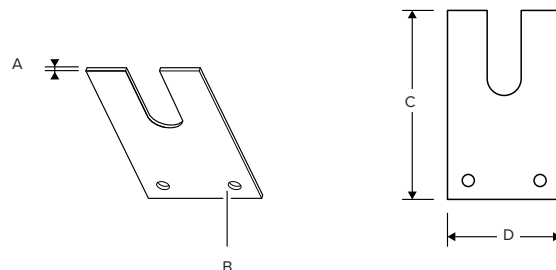
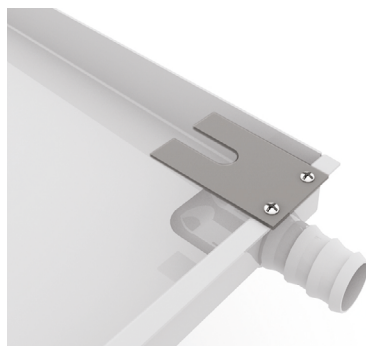

- The mounting holes are pre-punched in the condensation tray
- Lacquered
- Thickness 1 mm
- 2 rivets for mounting are supplied as standard

	A	B	C	D
L (inches)	1/16"	1/8"	1 15/16"	1 3/16"
L (cm)	1	3.2	50	30

Code	8776.0701
------	-----------

90° angle piece

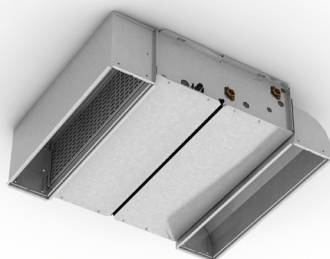

DIMENSIONS

Exhaust angle piece 90°

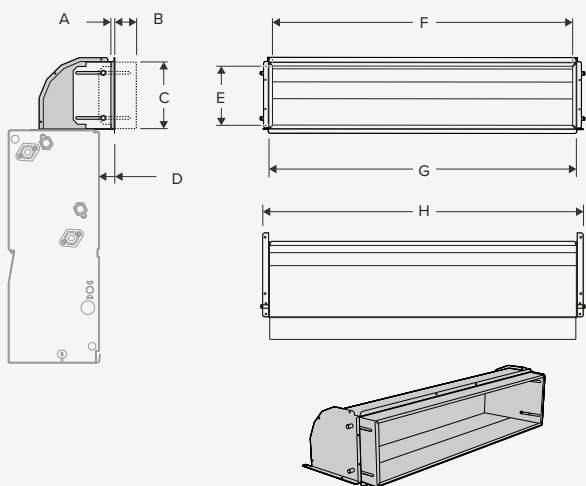

Model	T2 / 55	T3 / 75	T4 / 95	T6 / 125	T8 / 155	T10 / 190
Code	8788.0101	8788.0102	8788.0103	8788.0104	8788.0105	8788.0106
L (inches)	2 1/16"	2 7/8"	3 1/16"	4 13/16"	6 1/32"	7 5/8"
l (inches)	1 15/16"	2 3/4"	3 9/16"	4 3/4"	5 7/8"	7 1/2"
L (cm)	53	73	93	123	153	193
l (cm)	50	70	90	120	150	190

	A	B	C	D	E	F	G	H
L (inches)	3/8"	1 15/16"	5 7/8"	1 9/16"	5 5/16"	L-1"	l	L
L (cm)	1	5	15	4	13.5	L-2.5	l	L

DIMENSIONS

Inlet angle piece 90°

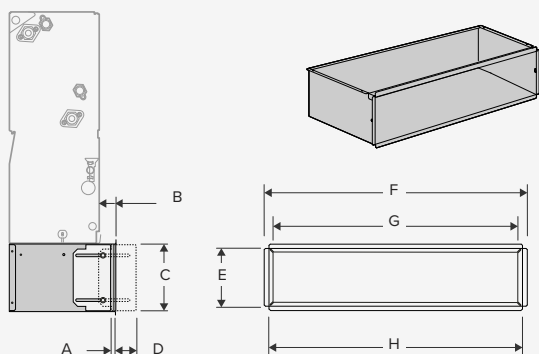

Model	T2 / 55	T3 / 75	T4 / 95	T6 / 125	T8 / 155	T10 / 190
Code	8787.0101	8787.0102	8787.0103	8787.0104	8787.0105	8787.0106
L (inches)	2 1/16"	2 7/8"	3 11/16"	4 13/16"	6 1/32"	7 5/8"
l (inches)	1 15/16"	2 3/4"	3 9/16"	4 3/4"	5 7/8"	7 1/2"
L (cm)	53	73	93	123	153	193
l (cm)	50	70	90	120	150	190

	A	B	C	D	E	F	G	H
L (inches)	3/8"	1 15/16"	5 7/8"	1 9/16"	5 5/16"	L-1"	l	L
L (cm)	1	5	15	4	13.5	L-2.5	l	L

Min. and max. extension of suction nozzle

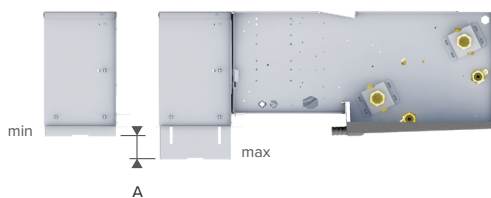

	A
L (inches)	2"
L (cm)	5

Assembly of the corner piece

- Remove the filter at the bottom of the appliance.
- Place this filter in the filter holder of the suction elbow. If not, the filter will no longer be accessible for maintenance or replacement after mounting the suction angle piece.
- When mounting the corner piece on the Briza 22 HP: first remove the pre-assembled flange.

DIMENSIONS FOR INSTALLATION INTO WALL WITH JAGA 90° EXHAUST ANGLE PIECE

BRIZA 22

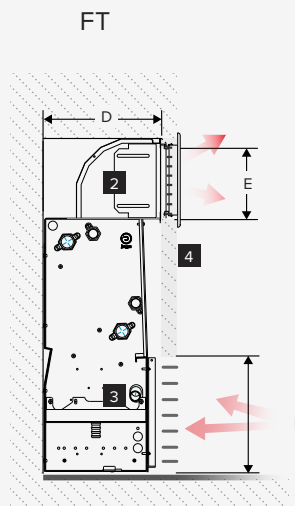
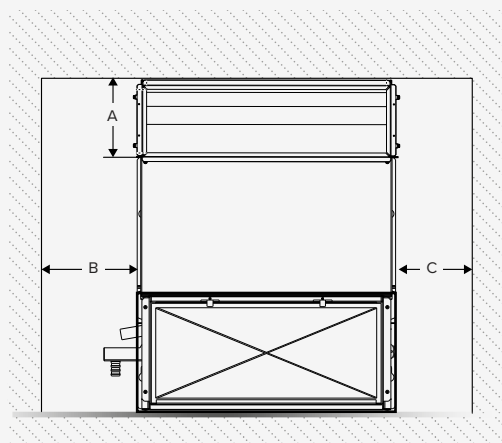

	A	B	C	D	E
L (inches)	6 1/16"	>7 7/8"	>5 7/8"	10 1/4"	>5 7/8"
L (cm)	17	>20	>15	26	>15

	F	G	H	I	J
L (inches)	>9 13/16"	>6 1/16"	>7 7/8"	>5 7/8"	10 1/4"
L (cm)	>25	>17	>20	>15	26

	K	L	M	N	O
L (inches)	>5 7/8"	>5 7/8"	10 1/4"	>5 7/8"	>5 7/8"
L (cm)	>15	>15	26	>15	>15

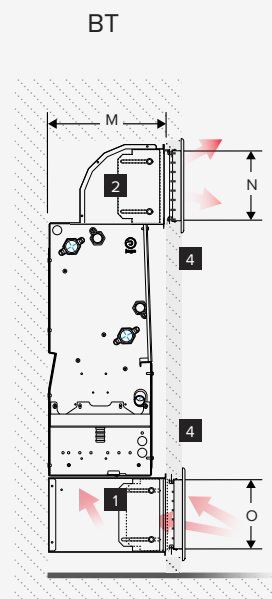
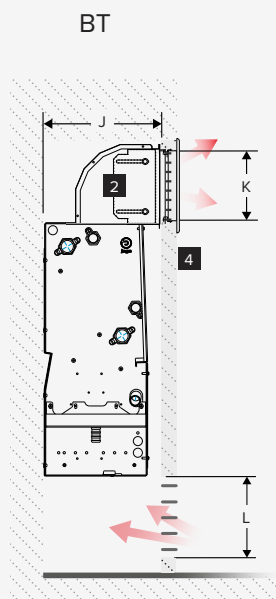
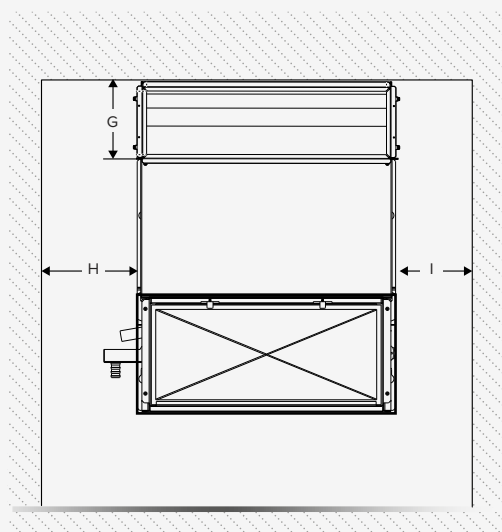

- 1** 90° inlet piece, 5 cm (2") extendable
- 2** 90° exhaust piece, 5 cm (2") extendable
- 3** front grille with filter
- 4** adjustable air inlet / exhaust grille, see page 50

Grids larger than 15 cm must be supplied by the installer. Not available from Jaga.

90° ANGLE PIECE

DIMENSIONS FOR INSTALLATION INTO CEILING WITH JAGA 90° EXHAUST ANGLE PIECE

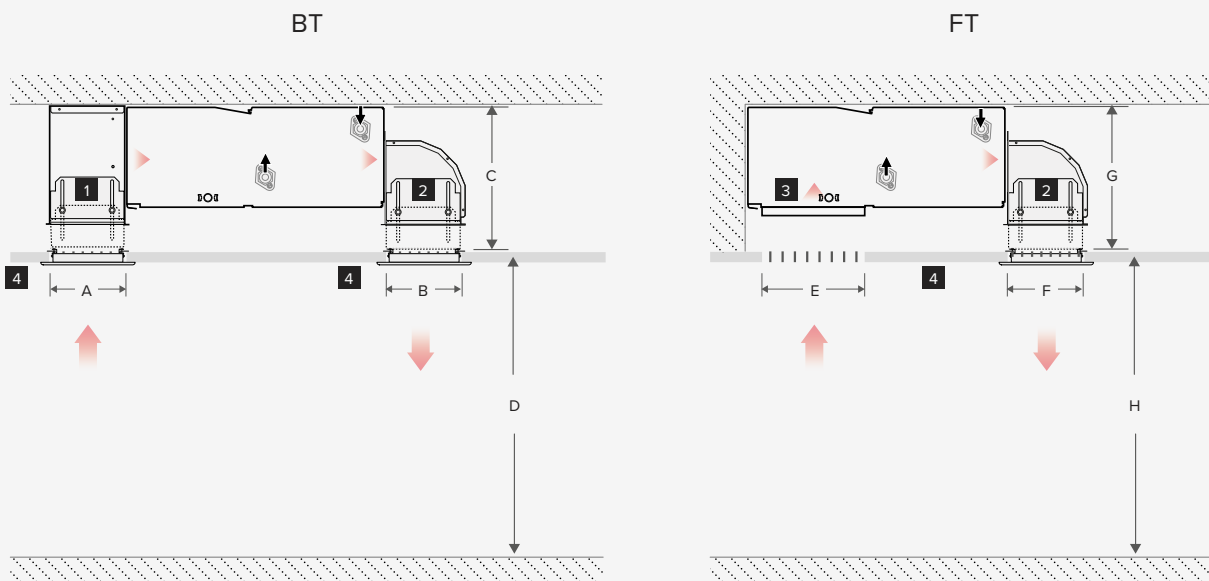

- 1** 90° inlet piece, 5 cm (2") extendable
- 2** 90° exhaust piece, 5 cm (2") extendable
- 3** front grille with filter
- 4** adjustable air inlet / exhaust grille, see page 50

Grids larger than 15 cm must be supplied by the installer. Not available from Jaga.

	A	B	C	D*	E	F	G	H*
L (inches)	>5 7/8"	>5 7/8"	10 1/4"	120"	>9 13/16"	>5 7/8"	10 1/4"	120"
L (cm)	>15	>15	>26	300	>25	>15	>26	300

*For heating application vertical air throw depends on water temperatures, fan speed and room geometry

BRIZA 22

90° ANGLE PIECE

Grille

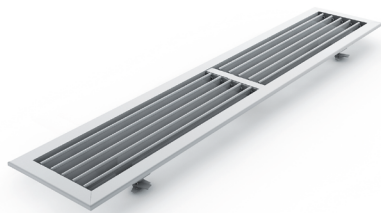

DIMENSIONS

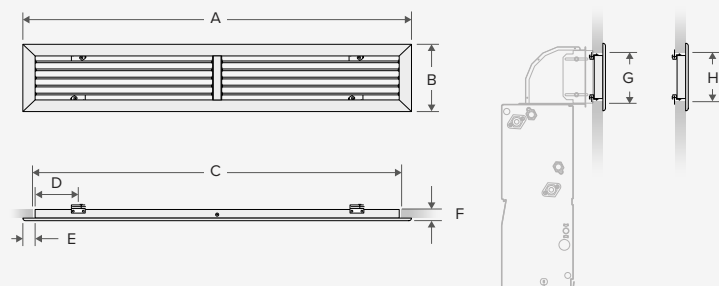

	A	B	C	D	E	F	G	H
L (inches)	L	7 3/16"	I	3 1/8"	1 1/16"	1"	5 7/8"	5 7/8"
L (cm)	L	18.2	I	8	2.7	2.6	15	15

MODEL	T2 / 55	T3 / 75	T4 / 95	T6 / 125	T8 / 155	T10 / 190
Code	8789.201	8789.202	8789.203	8789.204	8789.205	8789.206
L (inches)	20 15/16"	28 13/16"	36 11/16"	48 1/2"	60 5/16"	76 1/16"
l* (inches)	19 11/16"	27 9/16"	35 7/16"	47 1/4"	59 1/16"	74 13/16"
L (cm)	53.2	73.2	93.2	123.2	153.2	193.2
l* (cm)	50	70	90	120	150	190

*minimum dimensions cut-out for mounting of grille

BRIZA 22

GRILLE

Plenum connections

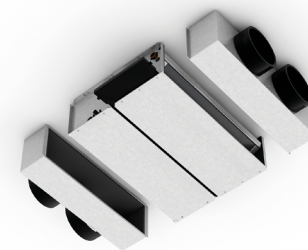

Exhaust Plenum connection

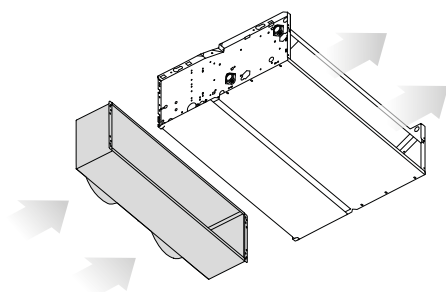

- Plenum with circular connection \varnothing 200 mm
- Inner side acoustically and thermally insulated
- Mounting on the outlet side of the device
- From galvanized steel
- Pressure losses are negligibly
- When mounting the plenum on the Briza 22 HP:
first remove the pre-assembled flange.

MODEL	T2 / 55	T3 / 75	T4 / 95	T6 / 125	T8 / 155	T10 / 190
Code	8764.0501	8764.0502	8764.0503	8764.0504	8764.0505	8764.0506

Inlet plenum connection

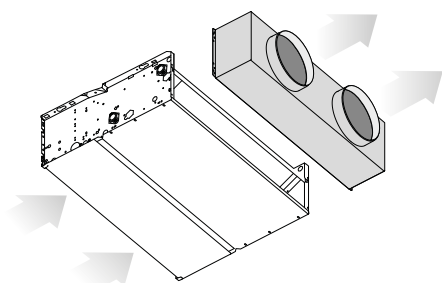

- Plenum with round connection \varnothing 200 mm
- Mount on the air inlet side of the unit
- From galvanized steel sheet
- Pressure losses are negligible
- When mounting the plenum on the Briza 22 HP:
first remove the pre-assembled flange.

MODEL	T2 / 55	T3 / 75	T4 / 95	T6 / 125	T8 / 155	T10 / 190
Code	8764.0601	8764.0602	8764.0603	8764.0604	8764.0605	8764.0606

DIMENSIONS

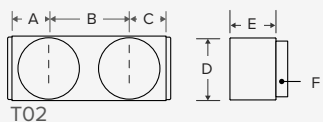

T02

	A	B	C	D	E	F
L (inches)	5 3/16"	9 1/4"	5 3/16"	8 1/4"	5 7/8"	Ø 7 7/8"
L (cm)	13.25	23.5	13.25	21	15	Ø 20

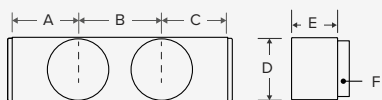

T03

	A	B	C	D	E	F
L (inches)	7 7/8"	11 13/16"	7 7/8"	8 1/4"	5 7/8"	Ø 7 7/8"
L (cm)	20	30	20	21	15	Ø 20

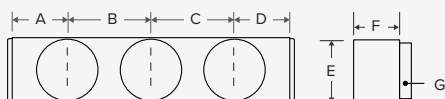

T04

	A	B	C	D	E	F	G
L (inches)	5 7/8"	11 13/16"	11 13/16"	5 7/8"	8 1/4"	5 7/8"	Ø 7 7/8"
L (cm)	15	30	30	15	21	15	Ø 20

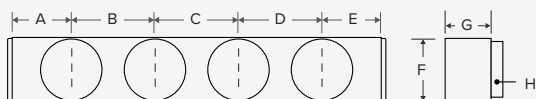

T06

	A	B	C	D	E	F	G	H
L (inches)	5 7/8"	11 13/16"	11 13/16"	11 13/16"	5 7/8"	8 1/4"	5 7/8"	Ø 7 7/8"
L (cm)	15	30	30	30	15	21	15	Ø 20

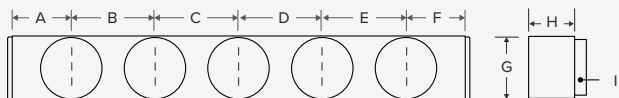

T08

	A	B	C	D	E	F	G	H	I
L (inches)	5 7/8"	11 13/16"	11 13/16"	11 13/16"	11 13/16"	5 7/8"	8 1/4"	5 7/8"	Ø 7 7/8"
L (cm)	15	30	30	30	30	15	21	15	Ø 20

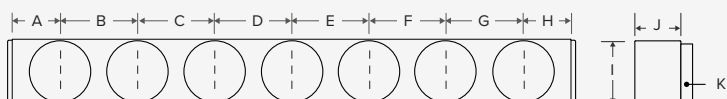

T10

	A	B	C	D	E	F	G	H	I	J	K
L (inches)	6 5/16"	10 1/16"	10 1/16"	10 1/16"	10 1/16"	10 1/16"	10 1/16"	6 5/16"	8 1/4"	5 7/8"	Ø 7 7/8"
L (cm)	16	25.5	25.5	25.5	25.5	25.5	25.5	16	21	15	Ø 20

BRIZA 22

180° PLENUM

Integrated on/off fan controller

JDPC.002

DPC.BRC320 (Heating/cooling two-pipe with room temperature sensor)

DPC.BRC340 (Heating/cooling four-pipe with room temperature sensor)

DPC.BR2220 (Heating/cooling two-pipe without room temperature sensor)

DPC.BR2240 (Heating/cooling two-pipe without room temperature sensor)

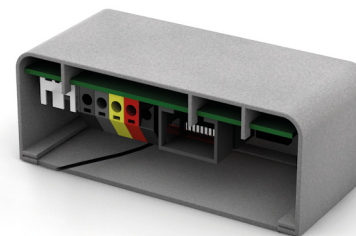

The room temperature sensor prevents the fan from starting when there is no dT between room temperature and water temperature, regardless of the water temperature.

- 24 VDC
- 0...10V OUT
- 0...10V IN Window contact
- T^{°r} sensor (room)
- T^{°w} sensor (water)
- T^{°o} sensor (water) Briza 4 pipe
- 8 different modes
- control:
 - no control panel
 - control panel Heating auto boost
 - control panel 3 positions Heating + Cooling
 - 3 key: Heating + Cooling
- valve control 2 Pipe / 4 Pipe

- Total cooling
- Sensible cooling
- Heating
- Standby / Off

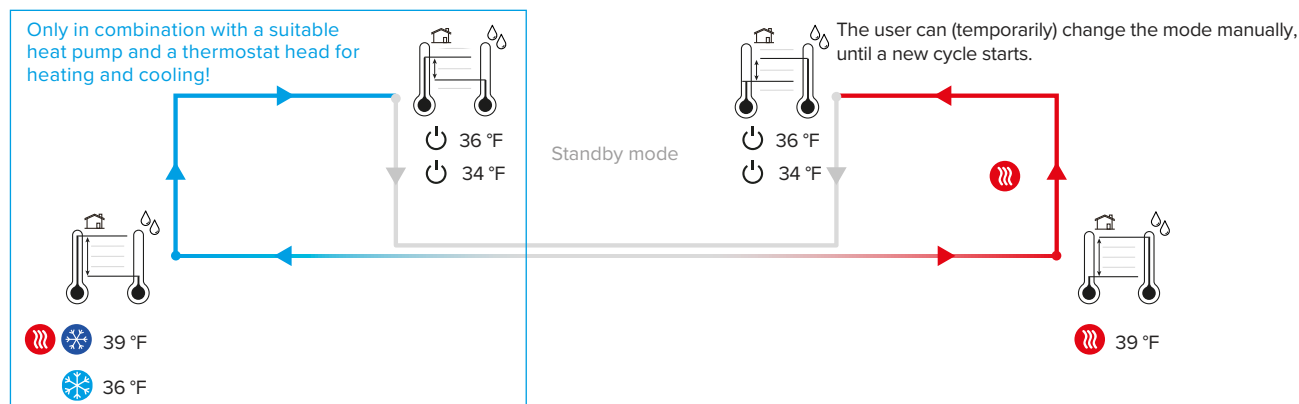

Heating:

The device automatically enters heating mode as soon as the water temperature is 39 °F higher than the room temperature. When the watertemperature has a difference smaller than 34 °F above the room temperature, the device automatically returns to standby.

Cooling:

The “total cooling” or “sensible cooling” function is programmed at the factory and depends on the type of device.

Total cooling:

The device automatically enters cooling mode as soon as the water temperature is 39 °F lower than the room temperature. When the water temperature has a difference smaller than 34 °F below the room temperature, the device automatically returns to standby.

Sensible cooling:

The device automatically enters cooling mode as soon as the water temperature is 36 °F lower than the room temperature. When the watertemperature has a difference smaller than 34 °F below the room temperature, the device automatically returns to standby.

Spare parts

ATTENTION!!

For replacement of defective parts, please contact the installer and consult the general Jaga Warranty Terms.

Filter

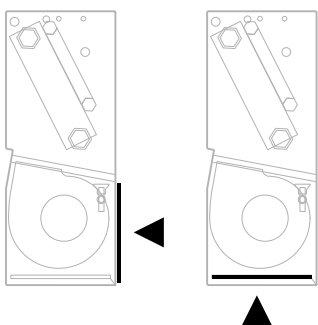

MODEL	T2 / 55	T3 / 75	T4 / 95	T6 / 125	T8 / 155	T10 / 190
Code	8721.401	8721.402	8721.403	8721.404	8721.405	8721.406

- ISO 16890: Coarse-40% - ePm10-50% / EN779-2012: G2-M5
- Fire-safe according to DIN 53438 (F1)

Standard primary coil: 2-pipe system heating - cooling, 4-pipe system cooling

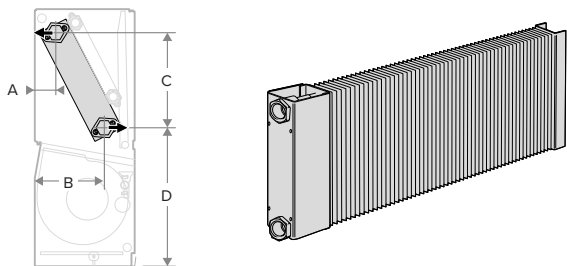

MODEL	T2 / 55	T3 / 75	T4 / 95	T6 / 125	T8 / 155	T10 / 190
Code	8776.0301	8776.0302	8776.0303	8776.0304	8776.0305	8776.0306

	A	B	C	D
L (inches)	1 ¹³ / ₁₆ "	5 ¹³ / ₁₆ "	7 ⁷ / ₈ "	11 ¹ / ₂ "
L (cm)	4.6	14.8	20	29.3

Secondary coil heating for 4-pipe ssystem

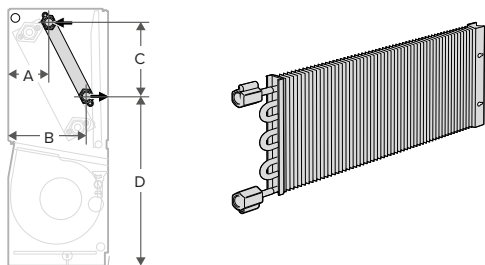

MODEL	T2 / 55	T3 / 75	T4 / 95	T6 / 125	T8 / 155	T10 / 190
Code	8721.5401	8721.5402	8721.5403	8721.5404	8721.5405	8721.5406

	A	B	C	D
L (inches)	3 7/16"	6 1/2"	6 1/8"	14"
L (cm)	8.7	16.6	15.6	35.6

Condensate drain pan wall

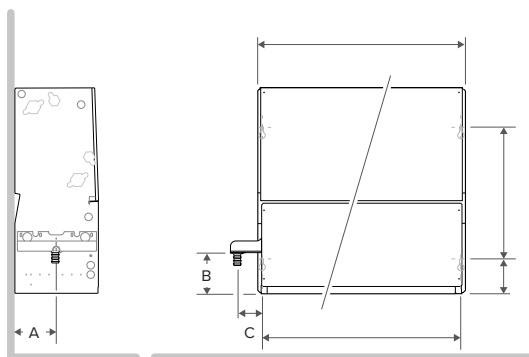

MODEL	T2 / 55	T3 / 75	T4 / 95	T6 / 125	T8 / 155	T10 / 190
Code	438.776.171.301					

	A	B	C
L (inches)	4 3/8"	4 1/8"	1 13/16"
L (cm)	11.1	10.5	4.6

Briza 22 Fan module

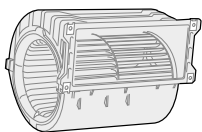

MODEL	T2 / 55	T3 / 75	T4 / 95	T6 / 125	T8 / 155	T10 / 190
24560.02200010	1x	-	-	1x	-	1x

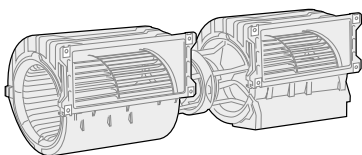

MODEL	T2 / 55	T3 / 75	T4 / 95	T6 / 125	T8 / 155	T10 / 190
24560.02200011	-	1x	1x	1x	2x	2x

Expected lifespan of the fans:

With an operation of 24 hours a day and 7 days a week at 70% power at a temperature of 68°F, the expected lifetime is 84.482 hours, or about 10 years. After this there is a 1% chance of dropout.

ONLY BRIZA 22 HP: High Performance Fan module

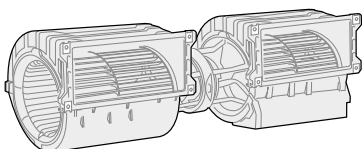

MODEL	-	T3 / 75	T4 / 95	T6 / 125	T8 / 155	T10 / 190
24560.02200014	-	1x	1x	-	1x	1x

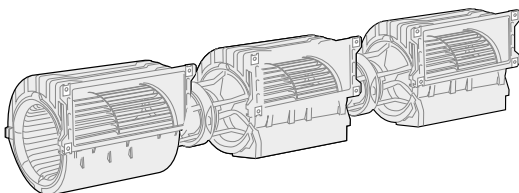

MODEL	-	T3 / 75	T4 / 95	T6 / 125	T8 / 155	T10 / 190
24560.02200015	-	-	-	1x	-	1x

Expected lifespan fans:

With an operation of 24 hours a day and 7 days a week at 70% power at a temperature of 68°F, the expected lifetime is 84.482 hours, or about 10 years. After this there is a 10% chance of dropout.

Flanges for duct connections

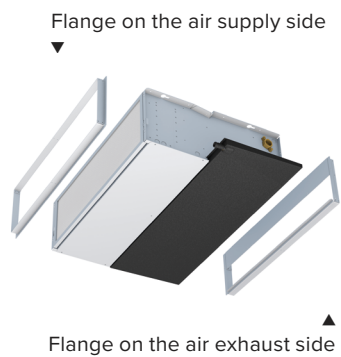

MODEL	-	T3 / 75	T4 / 95	T6 / 125	T8 / 155	T10 / 190
Code	-	8790.0102	8790.0103	8790.0104	8790.0105	8790.0106

MODEL	-	T3 / 75	T4 / 95	T6 / 125	T8 / 155	T10 / 190
Code	-	8791.0102	8791.0103	8791.0104	8791.0105	8791.0106

The installer must ensure an airtight seal between the duct and the flange.

Jaga reserves the right to change product specification at any time in line with our policy of continuous improvement and innovation.

Jaga Canada Climate Systems Inc.

375 University Ave. E.

Suite 205A

Waterloo, Ontario N2K 3M7

Canada

info@jaga-canada.com

www.jaga-canada.com

jaga CLIMATE DESIGNERS