

jaga CLIMATE DESIGNERS

CLIMA CANAL H13B32

I INSTALLATION INSTRUCTIONS



CONTENT

1. GENERAL INFORMATION	37
2. SYMBOLS	37
3. PRODUCT DESCRIPTION	39
4. TECHNICAL DATA	40
5. INSTALLATION	42
6. GUARANTEE	46

Important info



The unit must be installed by a certified installer in accordance with the installation instructions and the local building codes. Please follow this instruction manual and file it somewhere safe! The unit must always be accessible for maintenance and inspection.

Installation must be carried out by certified technicians. Incorrect installation could cause product failure, a reduced performance or an increased noise level.

The warranty is void when:

- The installation, maintenance or operation instructions in this manual are not respected.
- The initial start-up has been carried out before a general cleaning of both the fan and the coil.
- Modifications have been made to the product, before, during or after product installation.
- Maintenance has been carried out by unauthorized people.
- Access to the unit has been restricted due to on-site conditions.

This device is covered by the general warranty conditions of Jaga NV.

1. GENERAL INFORMATION

- Check for any visible damage.
- The unit must be handled with care in order to avoid damage to the unit's interior and exterior parts.
- The unit must remain accessible for inspection and maintenance, the trench must be removable at all times.
- Do not place any objects on the unit.
-  Do not insert objects into the supply and return air openings.

Unit identification:

The serial number is tagged on unit's right side (on the left if the connections are on the unit's right side).

Operational limits:

Installation that does not comply with the specified operational limits relieves Jaga NV from discharge liabilities with regard to damage to objects and persons.

- Max. water temperature: 90°C
- Maximum coil pressure: 20 bar.
- power supply voltage: 24 V  DC ±10 %

Use:

- The unit has been designed to function as a fan coil for both heating and cooling applications; any other use is strictly forbidden. Installing the unit in an explosive environment is prohibited.
- The area must be dry and dust-free, with a temperature between 5°C and 70°C and a relative humidity < 90%. (norm IEC EN 60335-2-40)
- The unit is not intended for industrial applications.
- Start-up and commissioning of the unit must be carried out by skilled staff, qualified to work on this type of product.

Maintenance:



- Maintenance must be carried out by qualified technicians.
-  Always use the main disconnect switch to isolate the unit from the mains before carrying out any maintenance or inspection work.
- A dirty grille obstructs the air flow, so clean the grille at regular intervals, depending on the room's purpose and how it's used. The grille should never be disassembled for maintenance and can be easily cleaned by using a vacuum cleaner.
- Do not use solvent- or detergent based products.
- Every 6 months: Check the condition of the coil and condensate drain.

Disassembly:

When the unit is not used for long periods of time, it must be disconnected from the mains electrical connection.

-  When the unit is not used for long periods of time, it must be disconnected from the mains electrical connection. If the unit is not used during the winter period, the water in the system may freeze. A suitable quantity of anti-freeze liquid should be mixed with the water. Mixing the water with glycol modifies the unit's performance. Pay attention to the safety instructions on the packaging regarding glycol.

Package:

-  Remove the packaging material and put it in the appropriate collection point or recycling facility, in compliance with the local regulations.
-  Do not leave the packaging within reach of children.

Installation

Installation must be carried out by certified technicians. Incorrect installation could cause product failure, a reduced performance or an increased noise level.

-  The unit might have sharp edges; use gloves during installation/adjustment.
- all clearances indicated in the manual must be respected in order to guarantee performance, and to allow installation and maintenance. In case valve packages are to be installed, make sure that there is enough room left.
- Sound travels very easily through hard materials. Soft rubber material can be used to reduce contact noise.
- With cooling: insulate the hydraulic pipes.
- When the condensate drain pipes are being connected, the pipe system must be sufficiently supported in order to prevent strain on the condensate drain tray.

Device installation guidelines:

- Do not insert objects into the supply and return air openings.

Starting:

 Start-up and commissioning of the fancoil must be carried out by skilled staff, qualified to work on this type of product.:

- The unit is positioned correctly.
- The supply and return pipes are properly connected and insulated.
- The pipes are clean and air is removed.
- The inclination of the unit towards the drain and the p-trap are correct.
- The wiring connections are correct and properly tightened.
- The supply voltage is correct.

2. SYMBOLS

 Danger

 Danger: electrical hazard

 Danger: sharp edges / components

 Danger: hot surfaces

 Danger: moving parts

 Attention: important warning

 Environmental safeguard

 VDC - direct current

 VAC - alternating current

3. PRODUCT DESCRIPTION

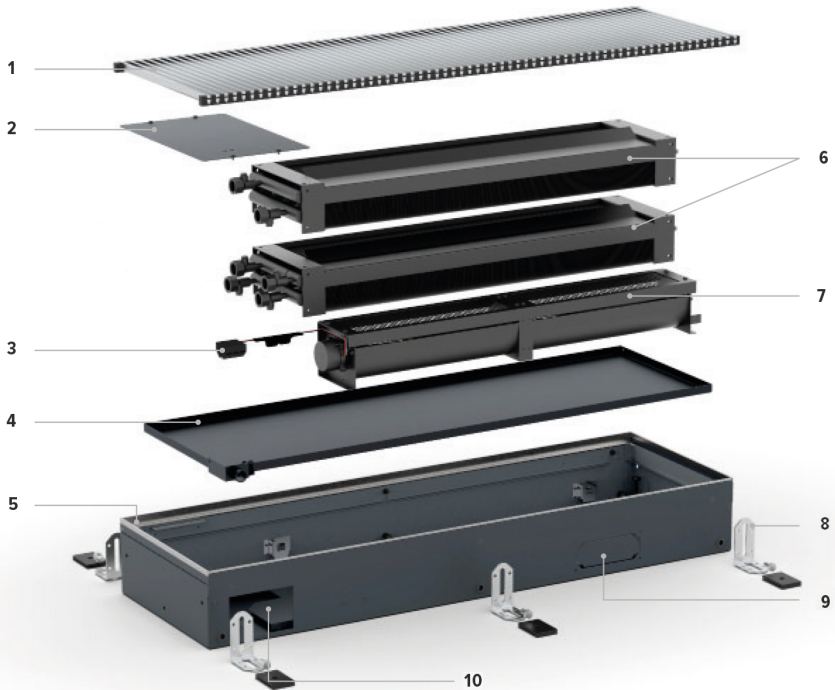

EN

1. Grille
2. Cover plate
3. Electrical connection on the inside
4. Condensate drain tray Ø20mm
5. Fine adjustment

6. Dynamic Low-H₂O coil (2-pipe and 4-pipe connection)
7. Thermal Activator(s) (tangential mini activator)
8. Height control, provided with acoustic decoupling (not fitted)
9. Fresh air connection (Option)
10. Hydraulic & electrical connection

4. TECHNICAL DATA

4.1. DIMENSIONS

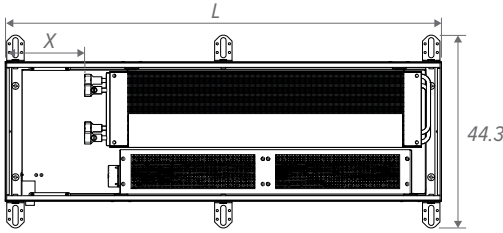
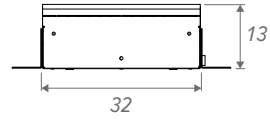
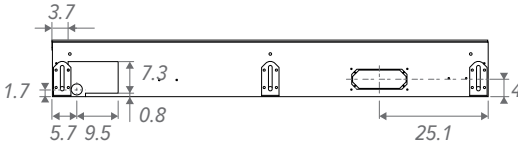

L (CM)	L (CM) <i>Doorlopende montage</i>	X (CM)
70.3	70.3	18.3
100.3	100.3	18.3
120.3	120.3	18.3
140.3	140.3	18.3
170.3	170.3	18.3
200.3	200.3	18.3
230.3	230.3	18.3
280.3	280.3	18.3
300.3	300.3	18.3

4.2. DIMENSIONS - HEIGHT ADJUSTMENT STANDARD

Height control, provided with acoustic decoupling

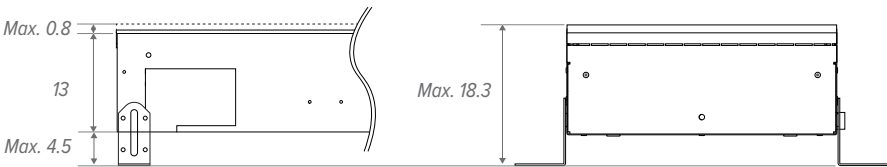

4.3. DIMENSIONS - FEET WITH HEIGHT ADJUSTMENT FOR RAISED FLOORS

Option: Feet with height adjustment for raised floors

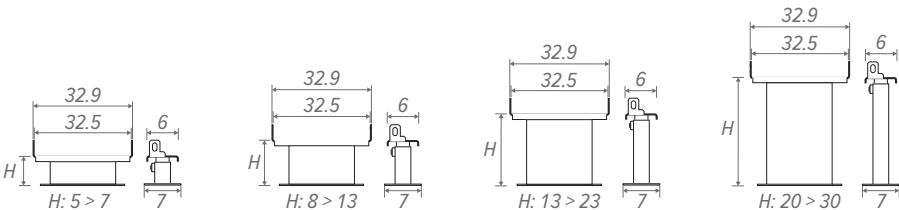

4.4. 24 VDC ELECTRICAL CONNECTION

Maximal cable length for a voltage drop less than 5%.

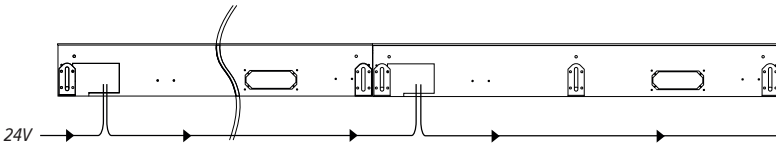

	CABLE LENGTH (M)	10	20	30	40	50	60	70	80	90	100
H13 B32 L70 (TYPE 1)	Ø 1 mm ²	9	4	3	2	1					
	Ø 1.5 mm ²	13	6	4	3	2			1		
	Ø 2.5 mm ²	22	11	7	5	4	3		2		
H13 B32 L100 (TYPE 2)	Ø 1 mm ²	7	3	2	1						
	Ø 1.5 mm ²	11	5	3	2		1				
	Ø 2.5 mm ²	19	9	6	4	3		2		1	
H13 B32 L120 (TYPE 3)	Ø 1 mm ²	6	3	1							
	Ø 1.5 mm ²	9	4	3	2	1					
	Ø 2.5 mm ²	15	7	5	3		2		1		
H13 B32 L140 (TYPE 4)	Ø 1 mm ²	6	3	1							
	Ø 1.5 mm ²	9	4	3	2	1					
	Ø 2.5 mm ²	15	7	5	3		2		1		
H13 B32 L170 (TYPE 5)	Ø 1 mm ²	4	2	1							
	Ø 1.5 mm ²	6	3	2	1						
	Ø 2.5 mm ²	10	5	3	2		1				
H13 B32 L200 (TYPE 6)	Ø 1 mm ²	3	1								
	Ø 1.5 mm ²	5	2	1							
	Ø 2.5 mm ²	9	4	3	2	1					
H13 B32 L230 (TYPE 7)	Ø 1 mm ²	3	1								
	Ø 1.5 mm ²	5	2	1							
	Ø 2.5 mm ²	9	4	3	2	1					
H13 B32 L280 (TYPE 8)	Ø 1 mm ²	2	1								
	Ø 1.5 mm ²	3	1								
	Ø 2.5 mm ²	6	3	2	1						
H13 B32 L300 (TYPE 9)	Ø 1 mm ²	2	1								
	Ø 1.5 mm ²	3	1								
	Ø 2.5 mm ²	5	2	1							

EN

5. INSTALLATION

 ALWAYS USE THE MAIN SWITCH TO ISOLATE THE POWER SUPPLY

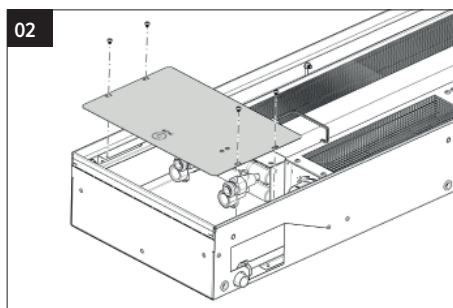
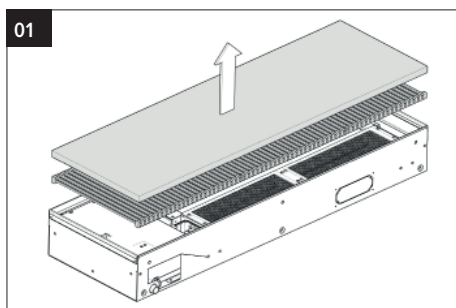

Remove the valve cover plate before installing the device.

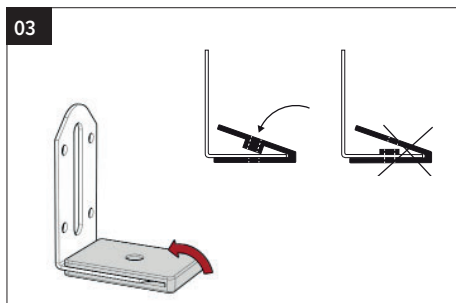

Mount the sound decoupler around each height adjuster

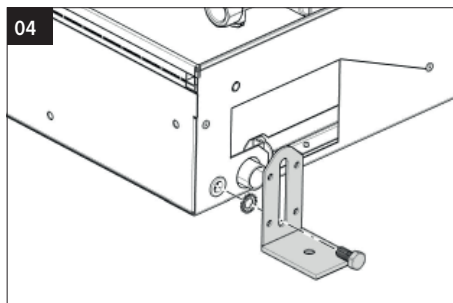

Fix the height adjusters to the casing. Do not completely tighten the bolt.

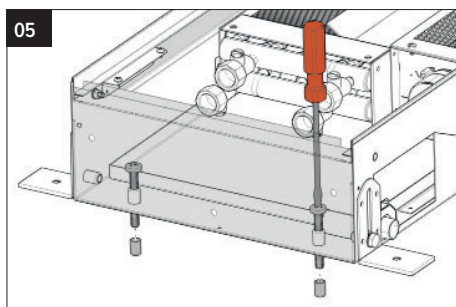

Unscrew the control screws in the bottom of the unit and place the plastic caps on the bottom of the screws to prevent vibrations and noise to the floor.

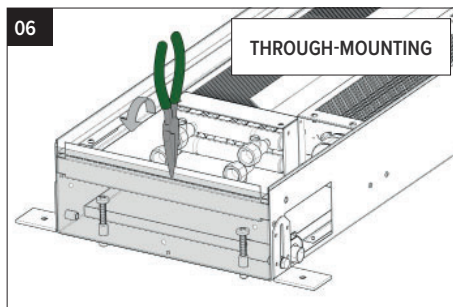

Break the metal strip on the short end of the casing (to enable continuous installation of the grille).

 Only on the ends that need to be connected

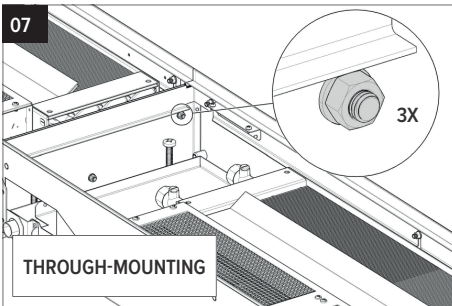

THROUGH-MOUNTING

Make sure that the units are positioned correctly and that the casings fit tightly. Use the supplied connecting pieces to connect the different units.

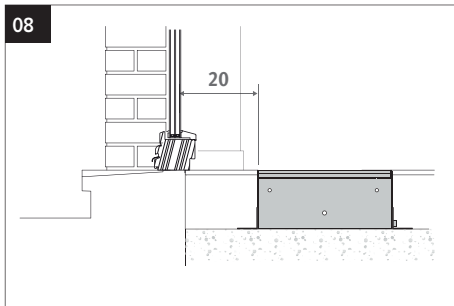

Install the device with the coil facing the wall or window.

! Curtains to the floor: Place the device at least 20 cm from the window.!

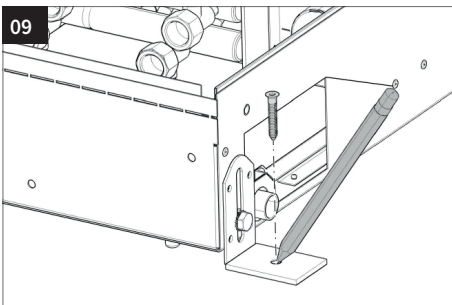

Mark the drill holes. Drill the holes and place the plugs. (Ø8mm). Fix the device to the floor, thanks to the height control in combination with the rubber sound decouplers.

! Use the correct plug for your floor type.

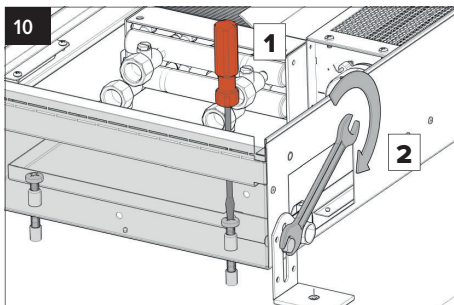

Use the control screws to adjust the unit to the desired height. Secure the height. Make sure that the top of the device is aligned with the finished floor.

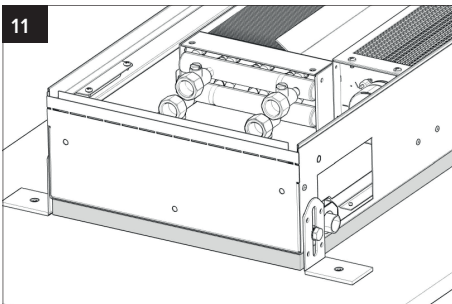

If the device is not mounted directly on the floor, the space under the device must be filled.

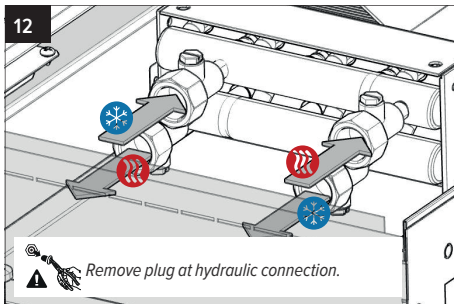

Hydraulic connection: Overview of the coil connections When using devices for cooling: iron couplings prohibited.

! Use a back-off wrench when fastening the hydronic connections



13

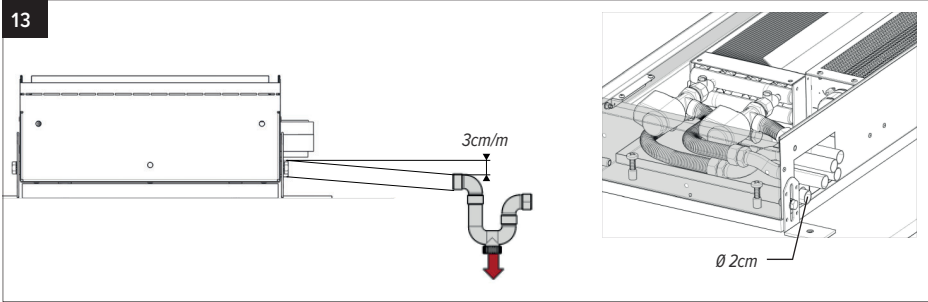

When the condensate drain pipes are being connected, the pipe system must be sufficiently supported in order to prevent strain on the condensate drain tray. The condensate drain system must be set up with an adequate p-trap in order to prevent the infiltration of odours. Always install a plug for cleaning in the lower part of the p-trap in order to allow quick disassembly. Pour water into the condensate collection pan and check if the liquid is drained properly. Otherwise, check the inclination and look for possible blockages.

14

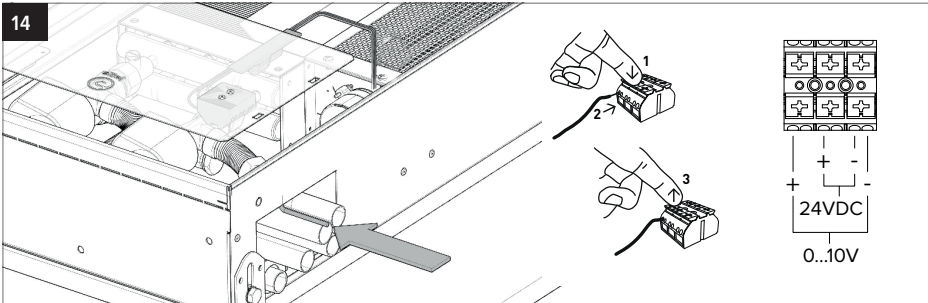

On the side of the hydraulic connection, you can also find the terminal block for the electrical connection. The electrical connection is connected in the black block, which is located at the bottom of the protective cover.

15

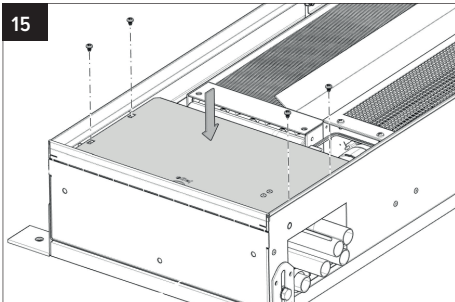

Mount the valve cover plate. Cover the casing with the protection foil and the protective cover.

⚠ This protective screen must remain on the unit during the entire construction phase.

16

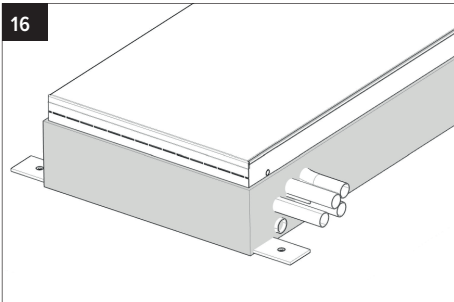

If screed is used the device needs to be completely insulated in order to protect the device from voltage differences.

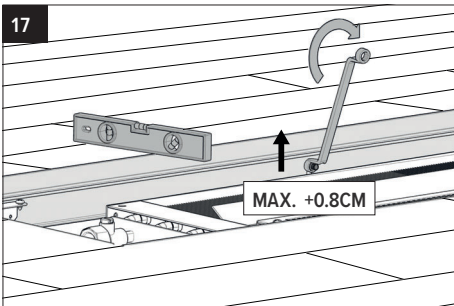

Fine adjustment to max. 0.8 cm, for a perfect alignment with the finished floor.

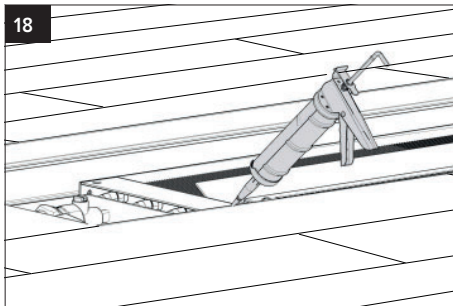

Apply the finishing touches.

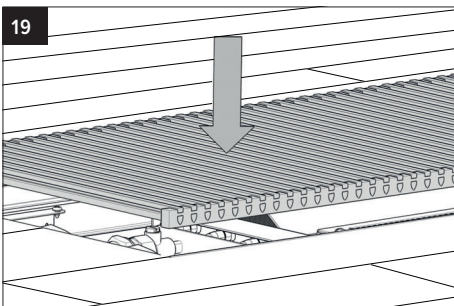

Install the grille.

6. GUARANTEE

1. The guarantee is valid only if the equipment is properly and correctly used, by its first owner and if installed in accordance with the norms and instructions as stipulated in the instruction leaflet and the current practices.
2. The guarantee only applies to the equipment and the spare parts. Jaga has the choice between repair and replacement of the equipment or the spare parts. If there has been a change in the model, Jaga is authorised to replace the guaranteed equipment with an equivalent equipment or equivalent spare parts. In those cases where the guarantee claim is received, during the first six months after the start of the guarantee, on all labour and transport costs.
3. The period of guarantee is mentioned in this certificate. A repair or replacement does not change anything to the original period of guarantee.
4. No guarantee is granted on equipment or spare parts lacking information concerning type or series, or on equipment where this information has been removed or altered, or on equipment that has been repaired or modified by persons not authorized by Jaga.
5. The customer is responsible for the damage in the cases where the damage is due to errors of placement, fittings, electrical connections, faulty or damaged electrical installations or appliances, erroneous voltage or hydraulic pressure and all other errors not related to the product delivered by Jaga. The guarantee is also revoked when nonsuited parts are applied. The guarantee for our heat exchangers is not valid if they are emptied at set times or during a certain period, or if they are heated by means of industrial water, steam or water saturated by great quantities of oxygen. The quality of the system water has to be in accordance with the VDI 2035-2 directives. The guarantee is also revoked when the heat exchangers are placed in aggressive atmospheric surroundings (ammonia, caustic substances). Lacquered radiators should not be used in humid spaces. Lacquered radiators should not be used in the following areas: above a bath with a built-in shower unit, in a shower cubical or next to it, in a swimming pool (chlorine) or in a sauna.
6. Jaga does not give a guarantee on faulty equipment due to incorrect handling and/or use of the equipment, the dropping of the equipment or the transport without the necessary precautions, or for all equipment that is built in, in a way that it cannot be reached normally. The guarantee is valid only if the equipment is properly and correctly used, by its first owner and if installed in accordance with the norms and instructions as stipulated in the instruction leaflet and the current practices.
7. In all cases where the guarantee is granted but where the intervention occurs later than 6 months after the start of the guarantee, and in all other cases, labour and transportation costs are calculated according to scales set by Jaga. Customers can get information on those scales either from our sales administration personnel, or from the maintenance engineer.
8. All interventions not covered by the guarantee have to be paid in cash to the maintenance engineer.
9. The guarantee starts on the date of the invoice. If the invoice is not available, the serial number or the date of production prevails.
10. Only the courts of judicial district Hasselt (Belgium) are authorised to deal with disputes arising from this guarantee. It will apply Belgian law even when sales involved are subjects of EU member states as well as non-EU member countries.



Jaga N.V., Verbindingslaan 16, B-3590 Diepenbeek
Tel.: +32 (0)11 29 41 11, Fax: +32 (0)11 32 35 78
info@jaga.be, www.jaga.com
27200.24600004 - 2023.01.09 - 10:26 - V.01