

BRIZA 12: STAND ALONE / BUILT-IN

INSTALLATION INSTRUCTIONS: BRIZA12 - WALL AND CEILING

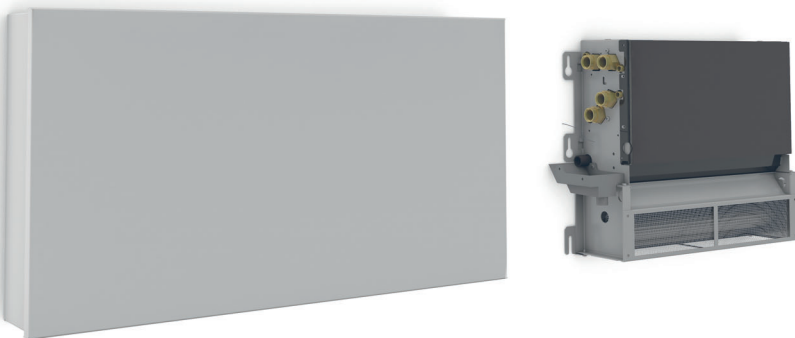
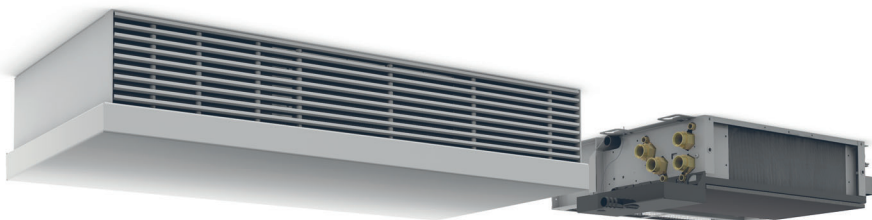

TABLE OF CONTENTS

1. USED SYMBOLS.....	3
2. WARNINGS AND SAFETY.....	4
3. PACKAGING AND COMPONENTS.....	4
4. INSTALLATION.....	4
5. GENERAL INFORMATION.....	5
6. PRODUCT DESCRIPTION.....	6
7. TECHNICAL DATA.....	7
8. OPERATING LIMITS.....	9
9. INSTALLATION.....	10
10. INITIAL START.....	14
11. MAINTENANCE.....	15
12. WARRANTY.....	16
13. DISSASSEMBLY INSTRUCTIONS.....	16

DECLARATION OF CONFORMITY

CEO JAGA N.V.
Jan Kriekels



26/03/2018

JAGA N.V. - Verbindingslaan 16 - B 3590, declares under its sole responsibility that the product to which this declaration relates: **BRIZA 12, BRIZA 22** is in conformity with the following standards or documents provided that these are used in accordance with our instructions: **NBN EN 60335-1 BASED ON EN60335-1:2012 + A11:2014 / NBN EN 60335-2-80 BASED ON EN 60335-2-80:2003 + A1:2004 + A2:2009**

Following the provision of Directives as amended:

- Low Voltage 2014/35/EC
- EMC 2014/30/EC
- Machinery 2006/42/EC
- RoHS 2011/65/EU



1. USED SYMBOLS



the DANGER sign warns the operator and maintenance staff about risks that may cause death, physical injury or illnesses of any kind.



DANGER: ELECTRICAL HAZARD



DANGER: SHARP EDGES



DANGER: HOT SURFACES



DANGER: MOVING PARTS



ATTENTION: IMPORTANT WARNING



the ENVIRONMENTAL SAFEGUARD sign provides instructions on how to use the unit in an ECO-friendly manner.



Important info

The unit must be installed by a certified installer in accordance with the installation instructions and the local building codes. Please follow this instruction manual and file it somewhere safe! The unit must always be accessible for maintenance and inspection.

The warranty is void when:

- the installation, maintenance or operation instructions in this manual are not respected.
- modifications have been made to the product, before, during or after product installation.
- maintenance has been carried out by unauthorized people.
- maintenance has been carried out by someone other than Jaga.
- access to the unit has been restricted due to on-site conditions.
- the initial start-up has been carried out before a general cleaning of both the fan and the coil.

2. WARNINGS AND SAFETY

Handling guidelines:

The unit must be handled with care in order to avoid damage to the unit's interior and exterior parts. The unit might have sharp edges; use gloves during installation/adjustment. All the operations listed below must be carried out in accordance with local health and safety regulations.

Storage conditions:

Up to four packaged units may be stacked on top of each other. All units must be stored in a dry area.

Technical spaces and positioning:



Incorrect installation of the unit may cause noise and vibrations issues.

3. PACKAGING AND COMPONENTS

Follow these instructions when removing the packaging:

- check for any visible damage
- open the packaging
- check if the manual is in the package
- remove the packaging material and put it in the appropriate collection point or recycling facility, in compliance with the local regulations.



Dispose of the packaging materials in compliance with the national or local regulations.



Do not leave the packaging within reach of children.

4. INSTALLATION

- installation must be carried out by certified technicians. Incorrect installation could cause product failure, a reduced performance or an increased noise level.
- the unit must be installed in accordance with the local building codes.
- Always use personal protective equipment.
- the unit must remain accessible for inspection and maintenance, the trench must be removable at all times.

4.1. ACOUSTIC INSULATION

Sound absorption

Sound is reflected by hard materials. Soft, porous materials are best suited for sound absorption. A combination of different materials can reduce the reflection of sound.

Contact noise insulation

Sound travels very easily through hard materials. Soft rubber material can be used to reduce contact noise. The effect of this insulation strongly depends on:

- installation method: make sure that vibrations cannot be transferred between different elements, e.g. between the built-in heaters and other metallic parts, through pipes, along air ducts etc.
- installation of acoustic insulation in hollow acoustic spaces. Avoid cavities between insulation and pipes.

5. GENERAL INFORMATION



DANGER!

The unit is not intended for industrial applications.

Do not insert objects into the supply and return air openings.



IMPORTANT!

- the unit will only function correctly if the installation and operation manual is strictly followed.
- all clearances indicated in the manual must be respected in order to guarantee performance, and to allow installation and maintenance.
- in case valve packages are to be installed, make sure that there is enough room left.
- periodic access to the unit is required for inspection, maintenance and repairs.
- pay attention to the signs and symbols indicated on the fan coil units.

Unit identification:

The serial number is tagged on unit's right side (on the left if the connections are on the unit's right side).

Information regarding unintended use:

The unit has been designed to function as a fan coil for both heating and cooling applications; any other use is strictly forbidden. Installing the unit in an explosive environment is prohibited.

Decommissioning:

When the unit is not used for long periods of time, it must be disconnected from the mains electrical connection.

If the unit is not used during the winter period, the water in the system may freeze. A suitable quantity of anti-freeze liquid should be mixed with the water.



Mixing the water with glycol modifies the unit's performance. Pay attention to the safety instructions on the packaging regarding glycol.

Restart after prolonged shutdown:

Before restarting:

- clean or replace the stainless steel fan guard.
- clean the coil.
- clean or unclog the condensate drain.
- bleed the air from the hydronic system.
- it is advisable to run the unit at maximum speed and to check for abnormalities.

Device description:

Jaga Briza 12 are fan coils for the treatment of air in indoor environments.

- maximal water temperature: 195°F
- test pressure: 377PSI
- working pressure: 290PSI
- power supply voltage: 24 V  DC ±10 %

6. PRODUCT DESCRIPTION

6.1. CEILING

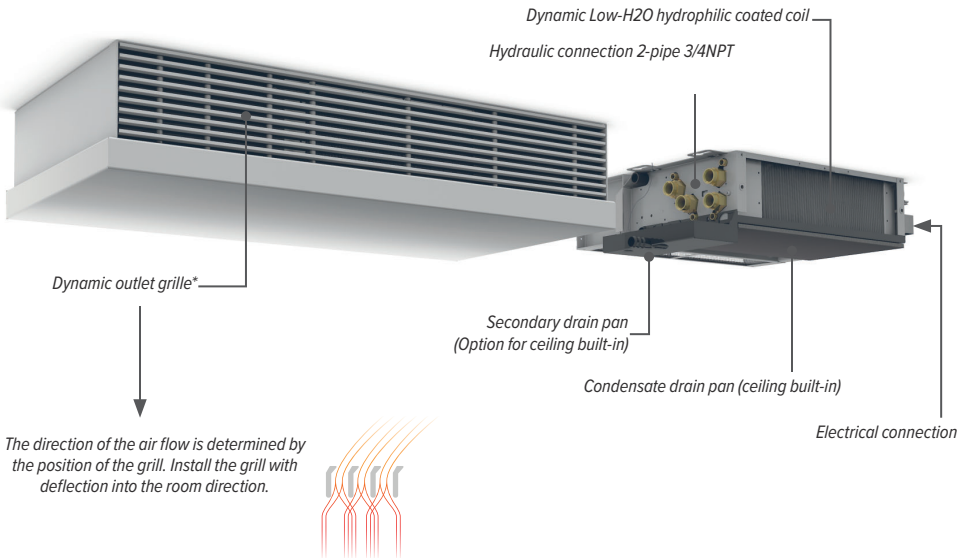

6.2. WALL

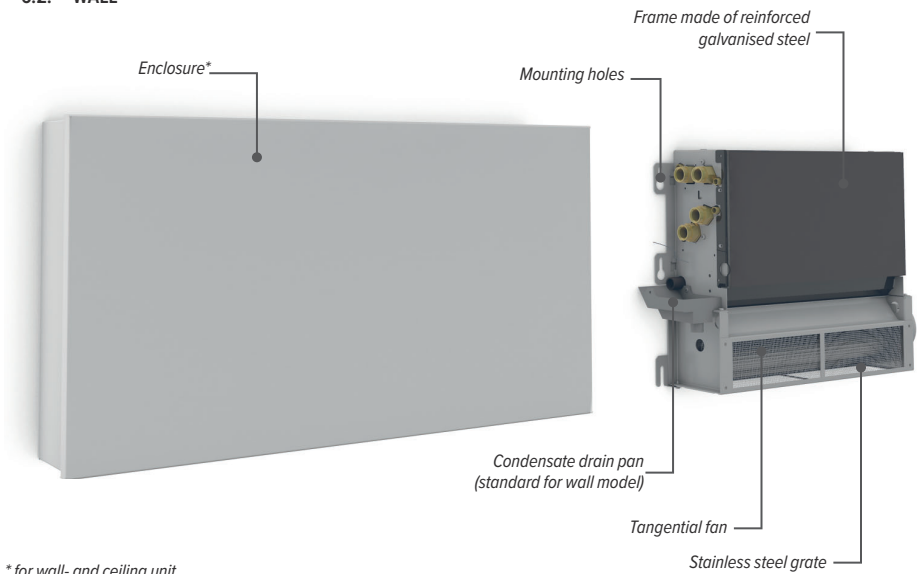

7. TECHNICAL DATA

7.1. DIMENSIONS WALL MOUNTED MODEL

7.1.1. Installation in a wall recess: Briza 038 / Briza 052

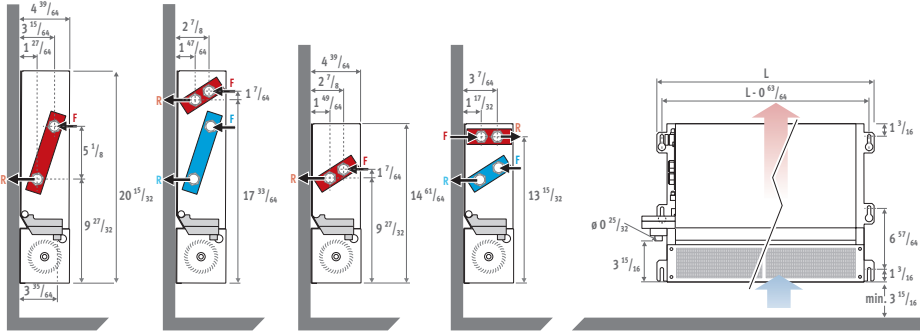

*Condensate drain tray: Standard for wall model / Option for in-ceiling installation

7.1.2. Wall mounting: Briza 041 / Briza 055

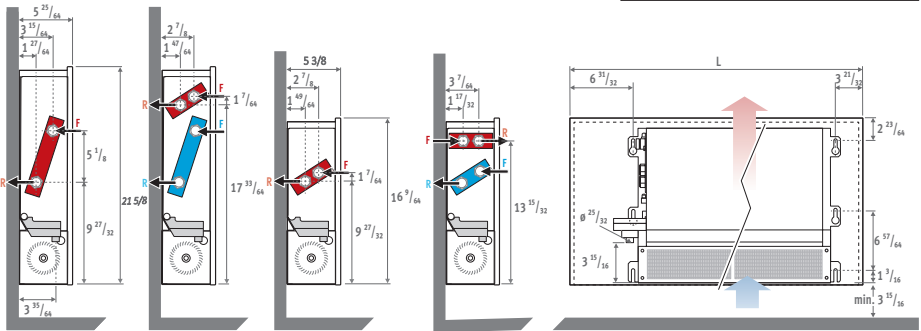
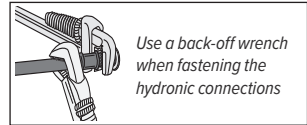

*Condensate drain tray: Standard for wall model / Option for in-ceiling installation

	L (INCH)			
BRIZA 038 / BRIZA 052	19 7/8	27 3/4	39 9/16	47 7/16
BRIZA 041 / BRIZA 055	29 17/32	37 13/32	49 7/32	57 3/32

7.2. DIMENSIONS CEILING-MOUNTED-MODEL

7.2.1. Built-in ceiling: Briza 038 / Briza 052

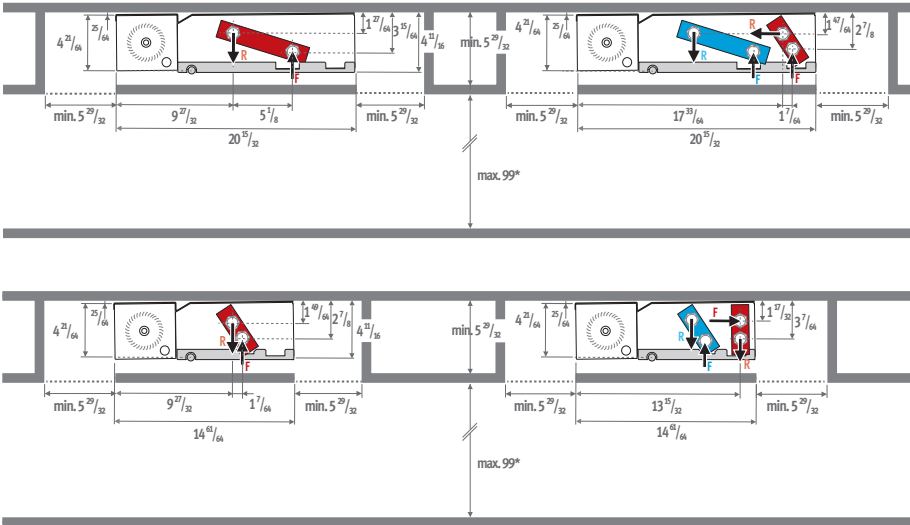

**Height restriction for heating applications only*

7.1.3. Ceiling mounting: Briza 041 / Briza 055

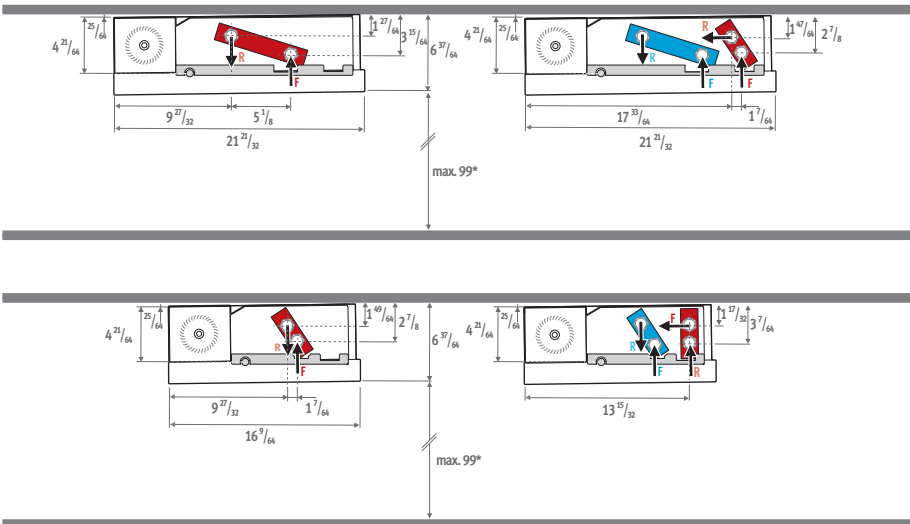

**Height restriction for heating applications only*

7.3. BUILT-IN MODEL WITH AIR OUTLET CORNER PIECE

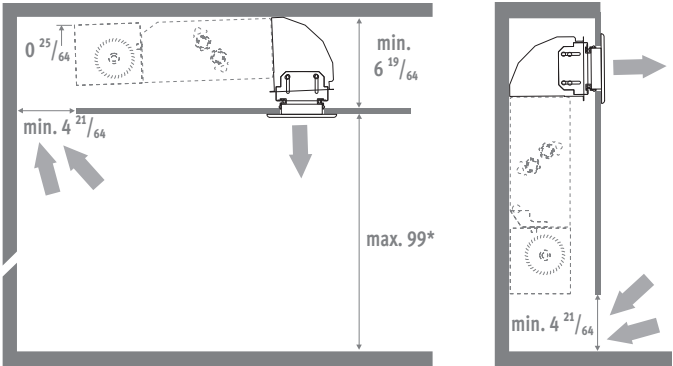

*Height restriction for heating applications only

8. OPERATING LIMITS

If the fancoil unit is supplied with chilled water, condensate from the coil will be drained via the condensate drain connection.

At water temperatures below dewpoint, condensation may occur on components other than the coil. This is not collected in the condensate drain, and might drip from under the unit.

Therefore the supply, return and drain pipes must be insulated. In case the valve package is installed next to the unit, the valve package must be insulated.

In order to avoid any condensation, the water temperature should be kept above the dewpoint. Output must be calculated based on the actual water temperatures and ambient air condition.

MINIMAL WATER TEMPERATURE (°C)

		AMBIENT TEMPERATURE / DRY BULB TEMPERATURE (°F)					
		69.8 °F	73.4 °F	77.0 °F	80.6 °F	84.2 °F	87.8 °F
RH (%)	40 %	37.4 °F	37.4 °F	37.4 °F	37.4 °F	37.4 °F	39.2 °F
	50 %	37.4 °F	37.4 °F	37.4 °F	37.4 °F	39.2 °F	42.8 °F
	60 %	37.4 °F	37.4 °F	39.2 °F	39.2 °F	42.8 °F	46.4 °F
	70 %	37.4 °F	39.2 °F	41.0 °F	42.8 °F	46.4 °F	50.0 °F
	80 %	39.2 °F	41.0 °F	42.8 °F	46.4 °F	50.0 °F	/
	90 %	41.0 °F	42.8 °F	46.4 °F	50.0 °F	/	/
100 %	42.8 °F	46.4 °F	50.0 °F	/	/	/	

Allowed minimal water temperatures before condensation occurs.

9. INSTALLATION

- Step 01 through 04 is only applicable to the wall. From step 05 the installation is identical for all Briza Built-In and Surface mount units.
- respect the open room around the unit as shown in the manual
- insulate the valves and connections and pipes with self-adhesive thermal insulation against condensation or install secondary drain pans
- slope the fancoil unit slightly towards the condensate drain to help the water drain

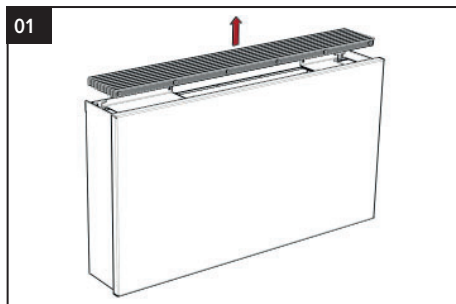

Remove the grille.

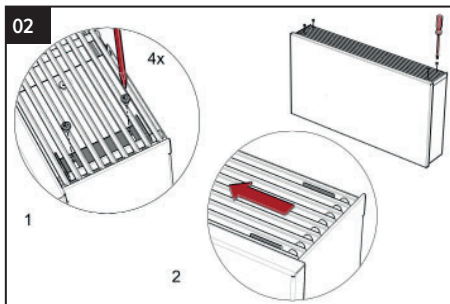

Only for ceiling surface mounted:
unscrew the grille holder
slide the holder to the side of the grille.

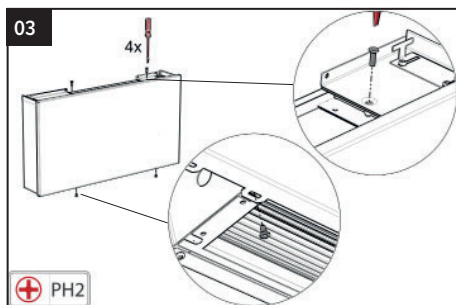

Remove the screws above and below the unit.

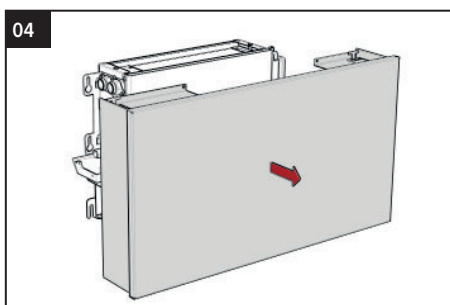

Remove the enclosure.

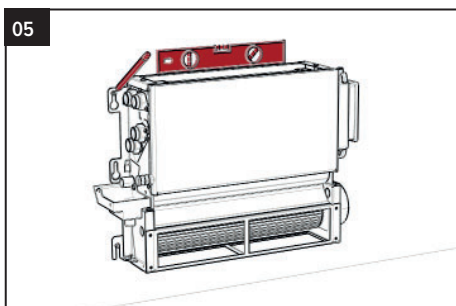

Mark the screw holes, use the unit as a template or according to the dimensions specified on page 8 and 10 in this guide.

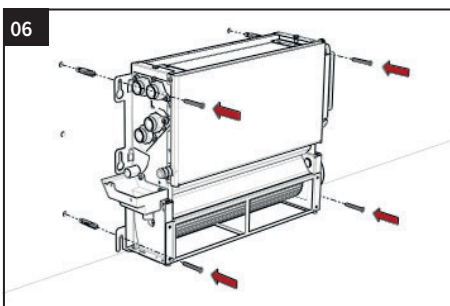

The type of wall determines what type of screw or plug should be used.
For installation on drywall: make sure that the mounting holes line up with supporting studs.

9.1. HYDRAULIC CONNECTION

 The hydraulic connections must be carried out by qualified staff.

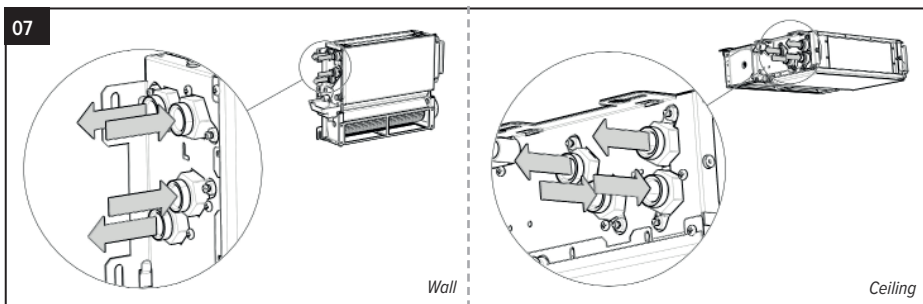

Connect the unit to the hydraulic system with the indicated inlet/outlet connections. Make sure the connections are air tight with a sealant.

–all coils (including the secondary coil) are equipped with an air vent near the top connection and a water drain near the lower connection.

–it is recommended to bleed air from the coil before operation.

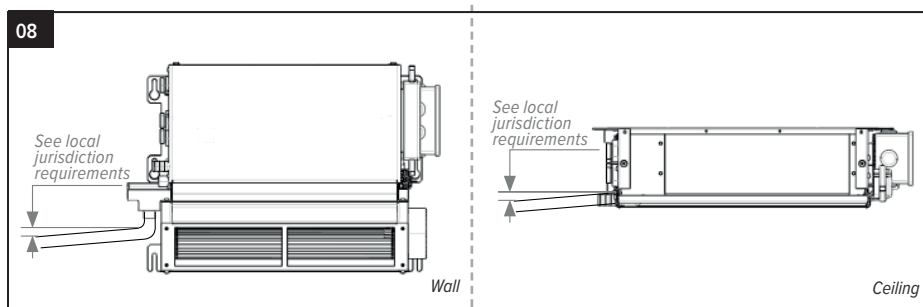

Setting up the condensate drain:

The condensate drain pipe must be installed with an adequate slope to make sure the water drains properly.

The supply and return pipes for chilled water and their valves must be insulated against condensation.

 Any piping downstream from the fan coil is the responsibility of the installing contractor and must comply with local jurisdiction requirements.

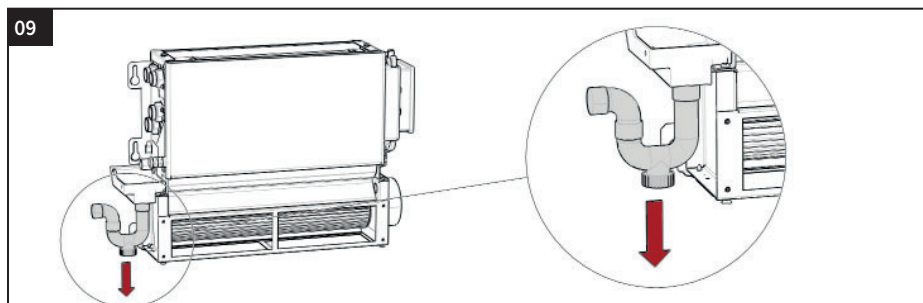

The condensate drain system must be set up with an adequate p-trap in order to prevent odours.

Always install a plug for cleaning in the lower part of the p-trap in order to allow quick disassembly.

Position the drain pipes without mechanical stress on the drain connection of the unit.

OPTION: secondary drain pan for Briza Built-In Ceiling

BRIZA H38: ref. 5127.00010001 / BRIZA H52: ref. 5127.00010002

Briza H38

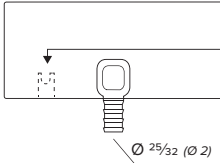
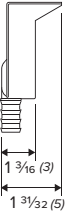
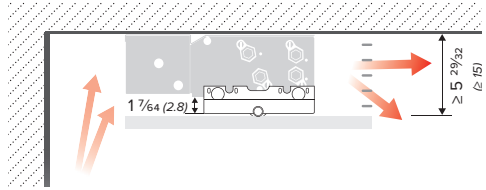
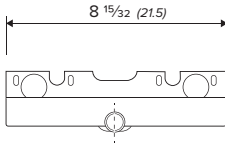

**Option: condensate float switch
ref. 5127.00010003**

switch features: Normally closed (NC)
white polypropylene silicone O-ring

CALUS
E316052

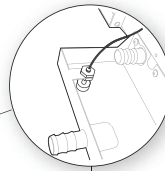

Briza H52

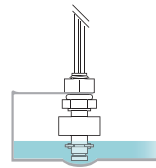
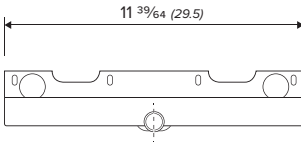

Type switch	10W (NC)
Max. switching current	0,25 A
Max. switching voltage	100V $\overline{\text{---}}$ DC
Max. temperature	176°F
Max. pressure	25 PSIG

Once installation is complete:

bleed the air from the coil

make sure that there are no water leaks

insulate the valve connections and pipes with self-adhesive thermal insulation against condensation or install secondary drain pans .

pour water into the condensate pan and check if the liquid is drained properly. If not, check the inclination and look for possible blockages.

9.2. ELECTRICAL CONNECTION



IMPORTANT!

The electrical connection of the unit must be carried out by a certified technician, in compliance with the local building codes. Non-conforming electrical connections releases Jaga N.V. from liability concerning damage to objects and persons.



DANGER!

- check that the voltage to each unit is 24VDC. The unit is designed for Direct Current only. In case 24AC comes to the unit, a suited rectifier must be installed.
- make sure that the power supply covers the total load of all units connected plus a margin of 10% to cover the start-up power.
- if the unit is mounted on a metal surface, the ground connection must be installed in compliance with local regulations. The ground conductor must be longer than the other conductors so that it is the last one to release in the event the connection comes loose.
- verify if the supply cables are of adequate section for the maximum current required.

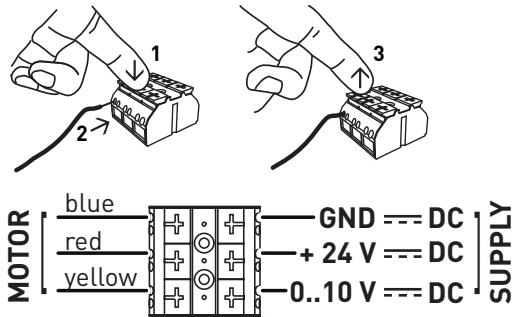

9.2.1. Option: Electrical connection - 0...10V

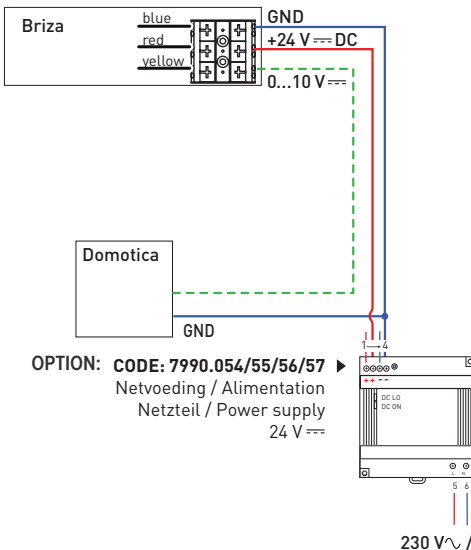

It is important to have a common ground on all power supplies used for power and control signal (for example from BMS or thermostat with speed control).

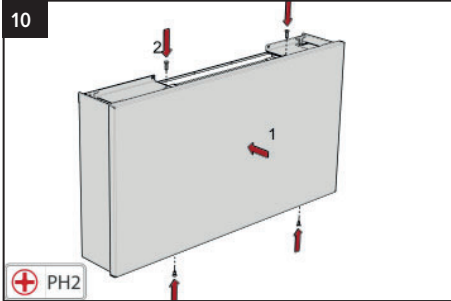

Units with enclosure:
Position the enclosure and attach the screw above and below the unit



Install the grill
⚠ The direction of the airflow is determined by the orientation of the grille.

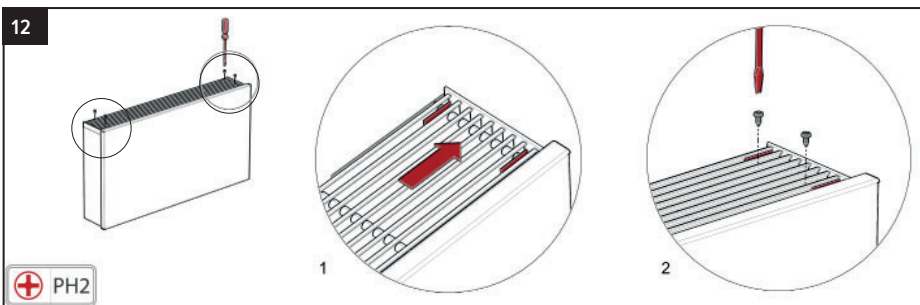

Only for Briza Ceiling (with enclosure): fasten the grill by the security clips

10. INITIAL START

⚠ IMPORTANT!

Start-up and Commissioning of the fancoil must be carried out by skilled staff, qualified to work on this type of product.

⚠ DANGER!

Before start-up, make sure the installation has been carried out in compliance with in this manual.

Before start-up the fancoil unit, check if:

1. the unit is positioned correctly
2. the supply and return pipes are properly connected and insulated
3. the pipes are clean and air is removed
4. the inclination of the unit towards the drain and the p-trap are correct
5. the coils are clean
6. the wiring connections are correct and properly tightened
7. the supply voltage is correct
8. the electric power consumption is correct and does not exceed the maximum value indicated in the catalog

11. MAINTENANCE



DANGER!

- maintenance must be carried out by qualified technicians.
- do not insert sharp objects into the supply and return grilles
- the unit has sharp edges; use gloves during maintenance!



DANGER!

Always use the main disconnect switch to isolate the unit from the mains before carrying out any maintenance or inspection work. Make sure that no one accidentally turns on the power to the unit; lock the master switch in the off position.

11.1. SPECIAL NOTE

Maintenance and cleaning of the stainless steel protection grille:

a dirty grille obstructs the air flow, so clean the grille at regular intervals, depending on the room's purpose and how it's used. The grille should never be disassembled for maintenance and can be easily cleaned by using a vacuum cleaner.

Cleaning the unit:

always disconnect the power supply before servicing the fan!!

- cleaning at regular intervals is important, depending on the room's purpose and how it's used
- clean with a vacuum cleaner or air compressor. Do not use solvent- or detergent based products.

11.2. ROUTINE MAINTENANCE

Every 6 months: Check the condition of the coil and condensate drain:

If necessary:

- remove any dirt from the coil surface
- remove dust using an air compressor
- wash with water and brush gently
- dry by using compressed air
- keep the condensate drain free from any obstructions that may prevent normal water flow

Bleed air from the system.

1. start the circulation pump and open the supply valve for a few minutes.
2. stop the circulation pump.
3. loosen the vent screw on the inlet collector and bleed the air.
4. repeat steps 1 to 3 until there is no more air escaping the system

11.3. ELECTRICAL CIRCUIT

The following steps are recommended to perform maintenance on the electrical circuit:

- check the unit's power consumption using a clip-on meter and compare the reading with the values shown in the documentation;
- inspect the electrical contacts for corrosion and loose wires.

12. WARRANTY

The fan coil unit is intended strictly for conditioning the indoor climate. Any unintended use is strictly forbidden and voids all warranty on the product. Installation, maintenance and operation of the unit is only allowed for authorized staff.

Please follow these instructions carefully

The warranty is void when:

- the installation procedure has not been followed,
- the fan coil has not been periodically cleaned,
- the unit has been used in an improper or irresponsible manner,
- repairs have been carried out by others than Jaga,
- product modifications have been carried out by others, before or after the installation,
- the product is not accessible for cleaning or maintenance.

If you have any questions or complaints, please contact your supplier or installer. The copyright of these instructions is the property of Jaga.

13. DISSASSEMBLY INSTRUCTIONS



SAFEGUARD THE ENVIROMENT

Jaga cares about protecting the environment.

When the unit is dismantled it is important to strictly follow these procedures:

- the unit must be dismantled by a firm that is authorized to dispose of scrap machinery/products

The unit as a whole is composed of secondary raw materials and the following conditions must be met:

- if the unit contains antifreeze, then dispose of the antifreeze as indicated in the glycol supplier's instructions.
- the electronic components are considered special waste, and must be recycled as such
- the pipe insulation and the sound-absorbing lining must be removed and processed as urban waste

Please follow and file these instructions!

Jaga Canada Climate Systems
www.jaga-canada.com

27200.23700035 - 16.11.2021, 9:08 - Jaga Inc.